

DIGITAL NOTES

THERMODYNAMICS

B.Tech II Year I Semester

DEPARTMENT OF MECHANICAL ENGINEERING



MALLA REDDY COLLEGE OF ENGINEERING & TECHNOLOGY

(An Autonomous Institution – UGC, Govt.of India)

Recognizes under 2(f) and 12(B) of UGC ACT 1956

(Affiliated to JNTUH, Hyderabad, Approved by AICTE –Accredited by NBA & NAAC-“A” Grade-ISO 9001:2015 Certified)

MALLA REDDY COLLEGE OF ENGINEERING & TECHNOLOGY

Vision

* To establish a pedestal for the integral innovation, team spirit, originality and competence in the students, expose them to face the global challenges and become pioneers of Indian vision of modern society.

Mission

- * To become a model institution in the fields of Engineering, Technology and Management.
- * To impart holistic education to the students to render them as industry ready engineers.
- * To ensure synchronization of institute ideologies with challenging demands of International Pioneering Organizations.

QUALITY POLICY

- * To implement best practices in Teaching and Learning process for both UG and PG courses meticulously
- * To provide state of art infrastructure and expertise to impart quality education.
- * To groom the students to become intellectually creative and professionally competitive.
- * To channelize the activities and tune them in heights of commitment and sincerity, the requisites to claim the never-ending ladder of SUCCESS year after year.

MALLA REDDY COLLEGE OF ENGINEERING & TECHNOLOGY

II Year B. Tech ME-I Sem

L	T/P/D	C
3	0	3

ENGINEERING THERMODYNAMICS

Course Objectives:

1. To understand the concepts of energy transformation, conversion of heat into work.
2. To acquire knowledge about the fundamentals of thermodynamic laws, the concept of entropy, and principles.
3. To understand how the change of state results in a process.
4. To understand the various gas laws, psychrometric properties and chart.
5. To learn the importance of thermodynamic cycles, and the derivation of efficiency.

UNIT-I

Basics of thermodynamics:

System - Types of Systems - Control Volume - Macroscopic and Microscopic viewpoints - Thermodynamic Equilibrium- State, Property, Process, Cycle – Reversibility – Quasi static Process, Irreversible Process, Causes of Irreversibility – Work and Heat, Point and Path functions. Zeroth Law of Thermodynamics – Principles of Thermometry –Constant Volume gas Thermometer – Scales of Temperature – PMM I - Joule’s Experiment – First law of Thermodynamics – Corollaries – First law applied to a Process – applied to a flow system – Steady Flow Energy Equation.

UNIT-II

Limitations of the First Law - Thermal Reservoir, Heat Engine, Heat pump, Parameters of performance, Second Law of Thermodynamics, Kelvin-Planck and Clausius Statements and their Equivalence / Corollaries, PMM of Second kind, Carnot’s principle, Carnot cycle and its specialties, Clausius Inequality, Entropy, Principle of Entropy Increase – Energy Equation, Availability and Irreversibility – Thermodynamic Potentials, Gibbs and Helmholtz Functions, Maxwell Relations – Elementary Treatment of the Third Law of Thermodynamics.

UNIT-III

Pure Substances: p-V-T- surfaces, T-S and h-s diagrams, Mollier Charts, Phase Transformations – Triple point at critical state properties during change of phase, Dryness Fraction – Mollier charts – Various Thermodynamic processes and energy Transfer – Steam Calorimetry. Perfect Gas Laws – Equation of State, specific and Universal Gas constants – Various Non-flow processes, properties, end states, Heat and Work Transfer, changes in Internal Energy – Throttling and Free Expansion Processes – Flow processes – Deviations from perfect Gas Model – Vander Waals Equation of State.

UNIT-IV

Mixtures of perfect Gases : Mole Fraction, Mass fraction Gravimetric and volumetric Analysis – Dalton’s Law of partial pressure, Avogadro’s Laws of additive volumes – Mole fraction, Volume fraction and partial pressure, Equivalent Gas constant, Enthalpy, sp. Heats and Entropy of Mixture of perfect Gases, Vapour, and Atmospheric air - Psychrometric Properties – Dry bulb Temperature, Wet Bulb Temperature, Dew point Temperature, Thermodynamic Wet Bulb Temperature, Specific Humidity, Relative Humidity, saturated Air, Vapour pressure, Degree of saturation – Adiabatic Saturation – Psychrometric chart.

UNI-V

Power Cycles : Otto cycle, Diesel cycle, Dual Combustion cycles description and representation on P–V and T-S diagram, Thermal Efficiency, Mean Effective Pressures on Air standard basis – Comparison of Cycles. Basic Rankine cycle – Performance Evaluation.

TEXT BOOKS:

1. Engineering Thermodynamics, Special Edition. MRCET, McGrahill Publishers.
2. Engineering Thermodynamics / PK Nag /TMH, III Edition
3. Thermodynamics – J.P.Holman / McGrawHill

REFERENCE BOOKS:

1. Engineering Thermodynamics – Jones & Dugan
2. Thermodynamics – An Engineering Approach – Yunus Cengel & Boles /TMH
3. An introduction to Thermodynamics / YVC Rao / New Age
4. Engineering Thermodynamics – K. Ramakrishna / Anuradha Publisher

OUTCOMES:

1. Analyze the work and heat interactions associated with a prescribed process path and to perform a analysis of a flow system.
2. Quantify the irreversibilites associated with each possibility and choose an optimal cycle.
3. Able to analyse Mollier chart, and to find the quality of steam.
4. Able to analyze psychrometric chart, to estimate thermodynamic properties such as WBT, DBT, RH, etc.
5. Analyze the thermodynamic cycles and evaluate performance parameters.

COURSE COVERAGE

S.NO	NAME OF THE UNIT	NAME OF THE TEXTBOOK	CHAPTERS COVERED
1	Basic Concepts	Thermodynamics by P.K. Nag Engineering Thermodynamics – K. Ramakrishna	1,2,3 1,2
2	Limitations of the First Law	Thermodynamics by P.K. Nag	2,3,4
3	Pure Substances	Thermodynamics by P.K. Nag Engineering Thermodynamics – K. Ramakrishna	3,4,5,6 4,5,6
4	Mixtures of perfect Gases	Thermodynamics by P.K. Nag	3,4,5,6,7,8
5	Power Cycles	Thermodynamics by P.K. Nag	7,8,9,10

CONTENTS

S.No	Name of the Unit	Page No
1	Basic Concepts	2
2	Limitations of the First Law	18
3	Pure Substances	56
4	Mixtures of perfect Gases	73
5	Power Cycles	95
6	Question Bank	116
7	Case Study	123

POs for Mechanical Engineering

PO1	Engineering knowledge: Apply the knowledge of mathematics, science, engineering fundamentals, and an engineering specialization to the solution of complex engineering problems.
PO2	Problem analysis: Identify, formulate, review research literature, and analyze complex engineering problems reaching substantiated conclusions using first principles of mathematics, natural sciences, and engineering sciences.
PO3	Design/development of solutions: Design solutions for complex engineering problems and design system components of processes that meet the specified needs with appropriate consideration for the public health and safety, and the cultural, societal, and environmental considerations.
PO4	Conduct investigations of complex problems: Use research-based knowledge and research methods including design of experiments, analysis and interpretation of data, and synthesis of the information to provide valid conclusions.
PO5	Modern tool usage: Create, select, and apply appropriate techniques, resources, and modern engineering and IT tools including prediction and modeling to complex engineering activities with an understanding of the limitations.
PO6	The engineer and society: Apply reasoning informed by the contextual knowledge to assess societal, health, safety, legal and cultural issues and the consequent responsibilities relevant to the professional engineering practice.
PO7	Environment and sustainability: Understand the impact of the professional engineering solutions in societal and environmental contexts, and demonstrate the knowledge of, and need for sustainable development.
PO8	Ethics: Apply ethical principles and commit to professional ethics and responsibilities and norms of the engineering practice.
PO9	Individual and team work: Function effectively as an individual, and as a member or leader in diverse teams, and in multidisciplinary settings.
PO10	Communication: Communicate effectively on complex engineering activities with the engineering community and with society at large, such as, being able to comprehend and write effective reports and design documentation, make effective presentations, and give and receive clear instructions.
PO11	Project management and finance: Demonstrate knowledge and understanding of the engineering and management principles and apply these to one's own work, as a member and leader in a team, to manage projects and in multidisciplinary environments.
PO12	Life-long learning: Recognize the need for, and have the preparation and ability to engage in independent and life-long learning in the broadest context of technological change

PSOs for Mechanical Engineering

PSO1	Ability to analyze, design and develop Mechanical systems to solve the Engineering problems by integrating thermal, design and manufacturing domains.
PSO2	Ability to succeed in competitive examinations or to pursue higher studies or research.
PSO3	Ability to apply the learned Mechanical Engineering knowledge for the development of society and self.

PEOs for Mechanical Engineering

<p>PEO1: PREPARATION</p> <p>To provide sound foundation in mathematical, scientific and engineering fundamentals necessary to analyze, formulate and solve engineering problems.</p>	<ul style="list-style-type: none"> The basic requirement for any student is to become a successful graduate is to have basic knowledge on fundamentals. Therefore, the first and foremost the objective is defined as Preparation.
<p>PEO2: CORE COMPETANCE</p> <p>To provide thorough knowledge in Mechanical Engineering subjects including theoretical knowledge and practical training for preparing physical models pertaining to core field.</p>	<ul style="list-style-type: none"> Providing services as per the Government & Industrial development plans and thrust areas. Considering reports and projections of CII, ELIAP, AICTE, HRD etc., on industrial developments requirements.
<p>PEO3: INVENTION, INNOVATION AND CREATIVITY</p> <p>To make the students to design, experiment, analyze, interpret in the core field with the help of other inter disciplinary concepts wherever applicable.</p>	<ul style="list-style-type: none"> Preparing students to solve complex engineering problems, which require idea about inventing, innovation and creativity.
<p>PEO4: CAREER DEVELOPMENT</p> <p>To inculcate the habit of lifelong learning for career development through successful completion of advanced degrees, professional development courses, industrial training etc.</p>	<ul style="list-style-type: none"> Preparing students to become a successful person in his/her future.
<p>PEO5: PROFESSIONALISM</p> <p>To impart technical knowledge, ethical values for professional development of the student to solve complex problems and to work in multi-disciplinary ambience, whose solutions lead to significant societal benefits.</p>	<ul style="list-style-type: none"> Preparing students to become a successful entrepreneur who can meet the societal needs.

Blooms Taxonomy:

Bloom's Taxonomy is a classification of the different objectives and skills that educators set for their students (learning objectives). The taxonomy was proposed in 1956 by Benjamin Bloom, an educational psychologist at the University of Chicago. The terminology has been recently updated to include the following six levels of learning. These 6 levels can be used to structure the learning objectives, lessons, and assessments of your course.

:

1. Remembering: Retrieving, recognizing, and recalling relevant knowledge from long- term memory.
2. Understanding: Constructing meaning from oral, written, and graphic messages through interpreting, exemplifying, classifying, summarizing, inferring, comparing, and explaining.
3. Applying: Carrying out or using a procedure for executing, or implementing.
4. Analyzing: Breaking material into constituent parts, determining how the parts relate to one another and to an overall structure or purpose through differentiating, organizing, and attributing.
5. Evaluating: Making judgments based on criteria and standards through checking and critiquing.
6. Creating: Putting elements together to form a coherent or functional whole; reorganizing elements into a new pattern or structure through generating, planning, or producing.

Bloom's taxonomy is a set of three hierarchical models used to classify educational learning objectives into levels of complexity and specificity. The three lists cover the learning objectives in cognitive, affective and sensory domains. The cognitive domain list has been the primary focus of most traditional education and is frequently used to structure curriculum learning objectives, assessments and activities.

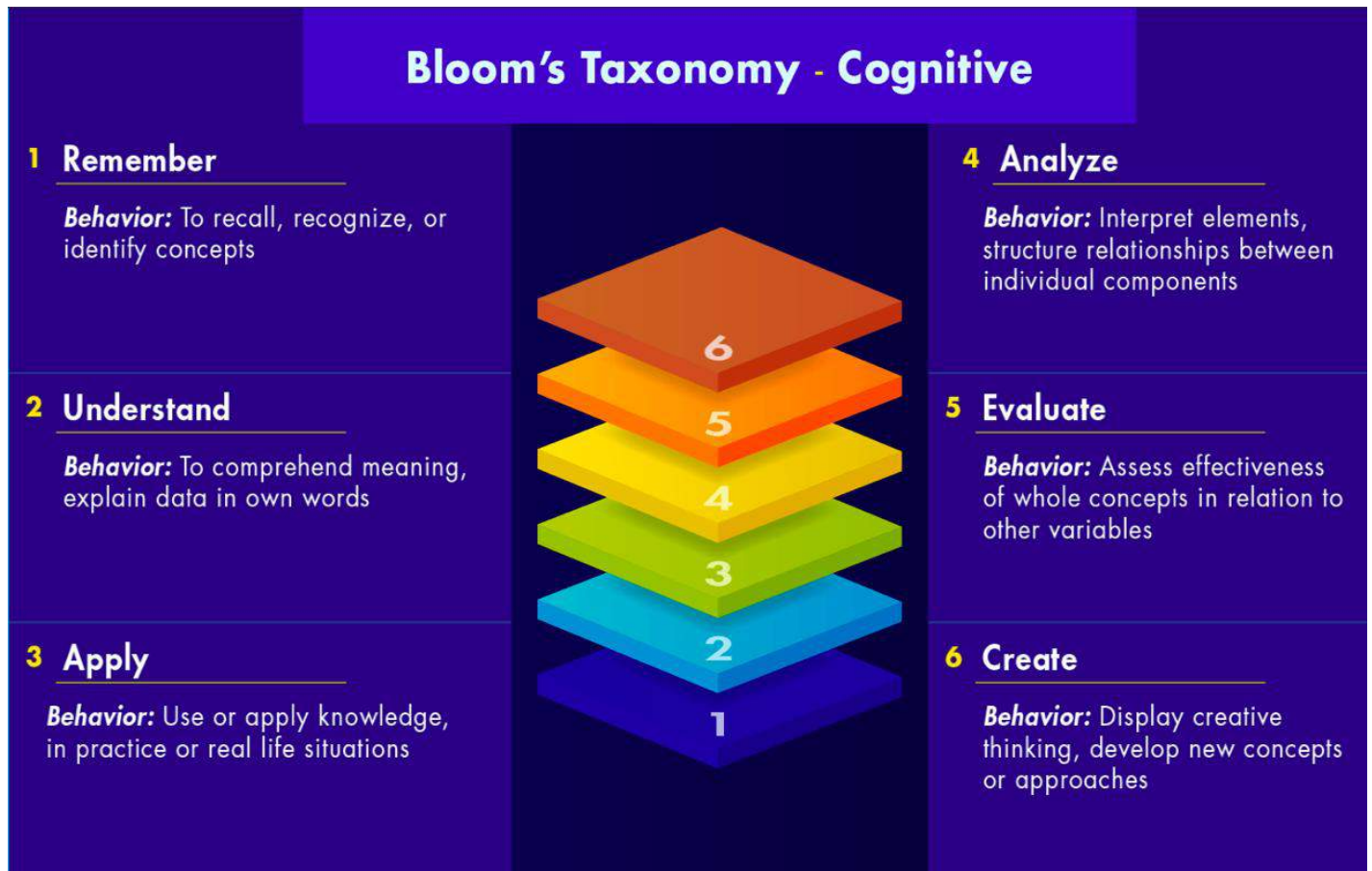

Mapping of Course Objectives

Engineering Thermodynamics (C111)	C111.1	Gain the knowledge on fluid mechanics fundamentals like fluid statics and fluid kinematics
	C111.2	Have basic idea about the fundamental equations used in Fluid Dynamics and are able to apply these concepts in real working environment
	C111.3	Study the fundamentals of turbo machinery and elements of hydroelectric power plant.
	C111.4	Measure the performance of the different types of Hydraulic Turbines
	C111.5	Calculate the performance of the different types of Hydraulic Pumps.

UNIT I

Basics of thermodynamics:

S.I. SYSTEM

Fundamental units of S.I system

Sr. No.	Physical quantities	Unit	symbol
1	Length	Metre	m
2	Mass	Kilogram	Kg
3	Time	Second	S
4	Temperature	Kelvin	K

Supplementary units of S.I. system

Sr. No.	Physical quantities	Unit	symbol
1	Plane angle	Radian	Rad

Principal S.I. units

Sr. No.	Physical quantities	Unit	symbol
1	Force	Newton	N
2	Work	Joule	J, N.m
3	Power	Watt	W
4	Energy	Joule	J, N.m
5	Area	Square metre	m ²
6	Volume	Cubic metre	m ³
7	Pressure	Pascal	Pa
8	Velocity/speed	metre per second	m/s
9	Acceleration	metre/second ²	m/s ²
10	Angular velocity	radian/second	rad/s
11	Angular acceleration	radian/second ²	rad/s ²
12	Momentum	kilogram metre/second	Kg.m/s
13	Torque	Newton metre	N.m
14	Density	Kilogram/metre ³	Kg/m ³
15	Couple	Newton.metre	N.m
16	Moment	Newton.metre	N.m

S.I. Prefixes

Multiplication factor	Prefix	Symble
10 ¹²	Tera	T
10 ⁹	Giga	G
10 ⁶	Mega	M
10 ³	kilo	k
10 ²	hecto	h
10 ¹	deca	da
10 ⁻¹	deci	d
10 ⁻²	centi	c
10 ⁻³	milli	m
10 ⁻⁶	micro	μ
10 ⁻⁹	nano	n
10 ⁻¹²	pico	p

Thermodynamics:

Thermodynamics is an axiomatic science which deals with the relations among heat, work and properties of system which are in equilibrium. It describes state and changes in state of physical systems.

System:

A thermodynamic system is defined as a quantity of matter or a region in space which is selected for the study.

Surroundings:

The mass or region outside the system is called surroundings.

Boundary:

The real or imaginary surfaces which separates the system and surroundings is called boundary. The real or imaginary surfaces which separates the system and surroundings is called boundary.

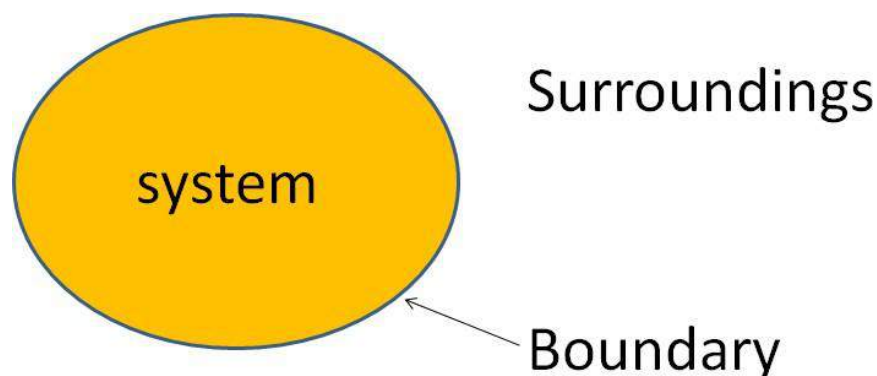
**Types of thermodynamic system**

On the basis of mass and energy transfer the thermodynamic system is divided into three types.

1. Closed system
2. Open system
3. Isolated system

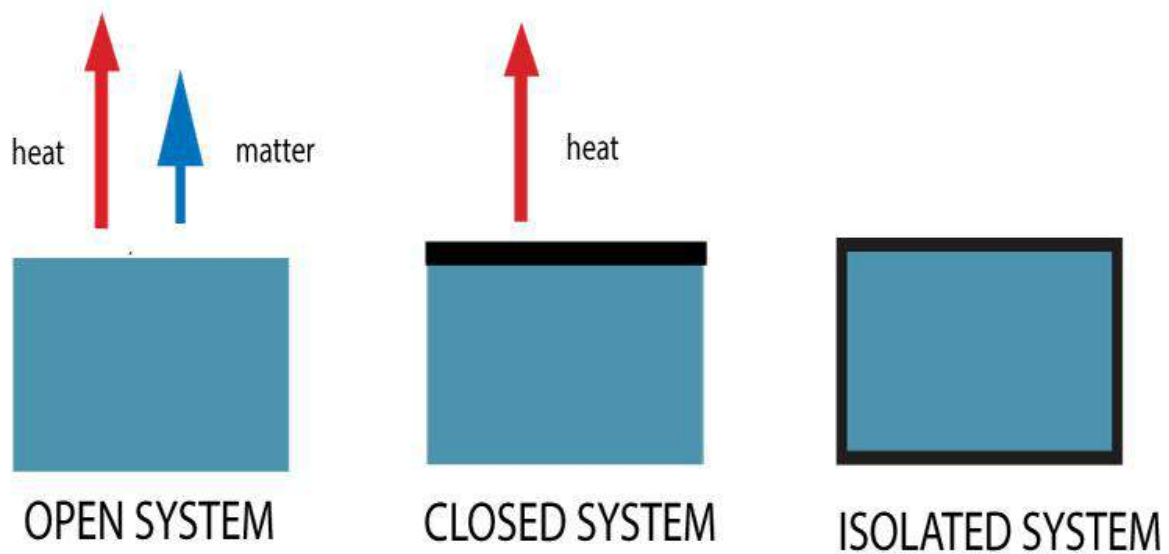

Closed system: A system in which the transfer of energy but not mass can take place across the boundary is called a closed system. The mass inside the closed system remains constant.

For example: Boiling of water in a closed vessel. Since the water is boiled in a closed vessel so the mass of water cannot escape out of the boundary of the system but heat energy continuously enters and leaves the boundary of the vessel. It is an example of a closed system.

Open system: A system in which the transfer of both mass and energy takes place is called an open system. This system is also known as a control volume.

For example: Boiling of water in an open vessel is an example of an open system because the water and heat energy both enter and leave the boundary of the vessel.

Isolated system: A system in which the transfer of mass and energy cannot take place is called an isolated system.

For example: Tea present in a thermos flask. In this, the heat and the mass of the tea cannot cross the boundary of the thermos flask. Hence, the thermos flask is an isolated system.

Control Volume:

- It's a system of fixed volume.
- This type of system is usually referred to as "open system" or a "control volume"
- Mass transfer can take place across a control volume.
- Energy transfer may also occur into or out of the system.
- Control Surface- It's the boundary of a control volume across which the transfer of

both mass and energy takes place.

- The mass of a control volume (open system) may or may not be fixed.
- When the net influx of mass across the control surface equals zero then the mass of the system is fixed and vice-versa.
- The identity of mass in a control volume always changes unlike the case for a control mass system (closed system).
- Most of the engineering devices, in general, represent an open system or control volume.

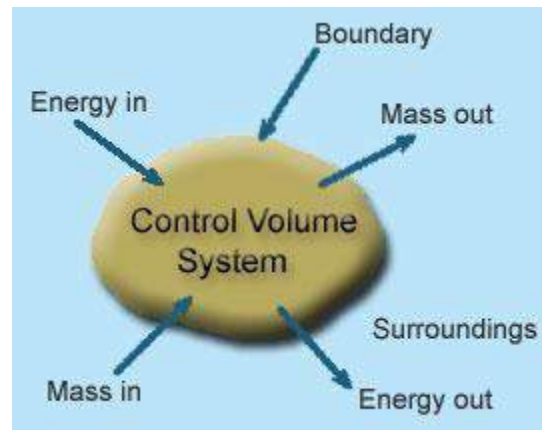

Example:

Heat exchanger - Fluid enters and leaves the system continuously with the transfer of heat across the system boundary.

Pump - A continuous flow of fluid takes place through the system with a transfer of mechanical energy from the surroundings to the system.

Microscopic View or Study:

- The approach considers that the system is made up of a very large number of discrete particles known as molecules. These molecules have different velocities and energies. The values of these energies are constantly changing with time. This approach to thermodynamics, which is concerned directly with the structure of the matter, is known as statistical thermodynamics.
- The behavior of the system is found by using statistical methods, as the number of molecules is very large. So advanced statistical and mathematical methods are needed to explain the changes in the system.
- The properties like velocity, momentum, impulse, kinetic energy and instruments cannot easily measure force of impact etc. that describe the molecule.
- Large numbers of variables are needed to describe a system. So the approach is complicated.

Macroscopic View or Study:

- In this approach a certain quantity of matter is considered without taking into account the events occurring at molecular level. In other words this approach to thermodynamics is concerned with gross or overall behavior. This is known as classical thermodynamics.
- The analysis of macroscopic system requires simple mathematical formula.
- The value of the properties of the system are their average values. For examples consider a sample of gas in a closed container. The pressure of the gas is the average value of the pressure exerted by millions of individual molecules.
- In order to describe a system only a few properties are needed.

S.No	Macroscopic Approach	Microscopic Approach
1	In this approach a certain quantity of matter is considered without taking into account the events occurring at molecular level.	The matter is considered to be comprised of a large number of tiny particles known as molecules, which moves randomly in chaotic fashion. The effect of molecular motion is considered.
2	Analysis is concerned with overall behavior of the system.	The Knowledge of the structure of matter is essential in analyzing the behavior of the system.
3	This approach is used in the study of classical thermodynamics.	This approach is used in the study of statistical thermodynamics.
4	A few properties are required to describe the system.	Large numbers of variables are required to describe the system.
5	The properties like pressure, temperature, etc. needed to describe the system, can be easily measured.	The properties like velocity, momentum, kinetic energy, etc. needed to describe the system, cannot be measured easily.
6	The properties of the system are their average values.	The properties are defined for each molecule individually.

7	This approach requires simple mathematical formulas for analyzing the system.	No. of molecules are very large so it requires advanced statistical and mathematical method to explain any change in the system.
---	---	--

Thermodynamic Equilibrium:

A thermodynamic system is said to exist in a state of thermodynamic equilibrium when no change in any macroscopic property is registered if the system is isolated from its surroundings.

An isolated system always reaches in the course of time a state of thermodynamic equilibrium and can never depart from it spontaneously.

Therefore, there can be no spontaneous change in any macroscopic property if the system exists in an equilibrium state. A thermodynamic system will be in a state of thermodynamic equilibrium if the system is the state of Mechanical equilibrium, Chemical equilibrium and Thermal equilibrium.

- Mechanical equilibrium: The criteria for Mechanical equilibrium are the equality of pressures.
- Chemical equilibrium: The criteria for Chemical equilibrium are the equality of chemical potentials.
- Thermal equilibrium: The criterion for Thermal equilibrium is the equality of temperatures.

State:

The thermodynamic state of a system is defined by specifying values of a set of measurable properties sufficient to determine all other properties. For fluid systems, typical properties are pressure, volume and temperature. More complex systems may require the specification of more unusual properties. As an example, the state of an electric battery requires the specification of the amount of electric charge it contains.

Property:

- Properties may be extensive or intensive.
- Intensive properties: The properties which are independent of the mass of the system. For example: Temperature, pressure and density are the intensive properties.

- Extensive properties: The properties which depend on the size or extent of the system are called extensive properties.
- For example: Total mass, total volume and total momentum.

Process:

When the system undergoes change from one thermodynamic state to final state due change in properties like temperature, pressure, volume etc, the system is said to have undergone thermodynamic process.

Various types of thermodynamic processes are: isothermal process, adiabatic process, isochoric process, isobaric process and reversible process.

Cycle:

Thermodynamic cycle refers to any closed system that undergoes various changes due to temperature, pressure, and volume, however, its final and initial state are equal. This cycle is important as it allows for the continuous process of a moving piston seen in heat engines and the expansion/compression of the working fluid in refrigerators, for example. Without the cyclical process, a car wouldn't be able to continuously move when fuel is added, or a refrigerator would not be able to stay cold. Visually, any thermodynamic cycle will appear as a closed loop on a pressure volume diagram.

Examples: Otto cycle, Diesel Cycle, Brayton Cycle etc.

Reversibility:

Reversibility, in thermodynamics, a characteristic of certain processes (changes of a system from an initial state to a final state spontaneously or as a result of interactions with other systems) that can be reversed, and the system restored to its initial state, without leaving net effects in any of the systems involved.

An example of a reversible process would be a single swing of a frictionless pendulum from one of its extreme positions to the other. The swing of a real pendulum is irreversible because a small amount of the mechanical energy of the pendulum would be expended in performing work against frictional forces, and restoration of the pendulum to its exact starting position would require the supply of an equivalent amount of energy from a second system, such as a compressed spring in which an irreversible change of state would occur.

Quasi static process:

When a process is processing in such a way that system will be remained infinitesimally close with equilibrium state at each time, such process will be termed as quasi static process

or quasi equilibrium process.

In simple words, we can say that if system is going under a thermodynamic process through succession of thermodynamic states and each state is equilibrium state then the process will be termed as quasi static process.

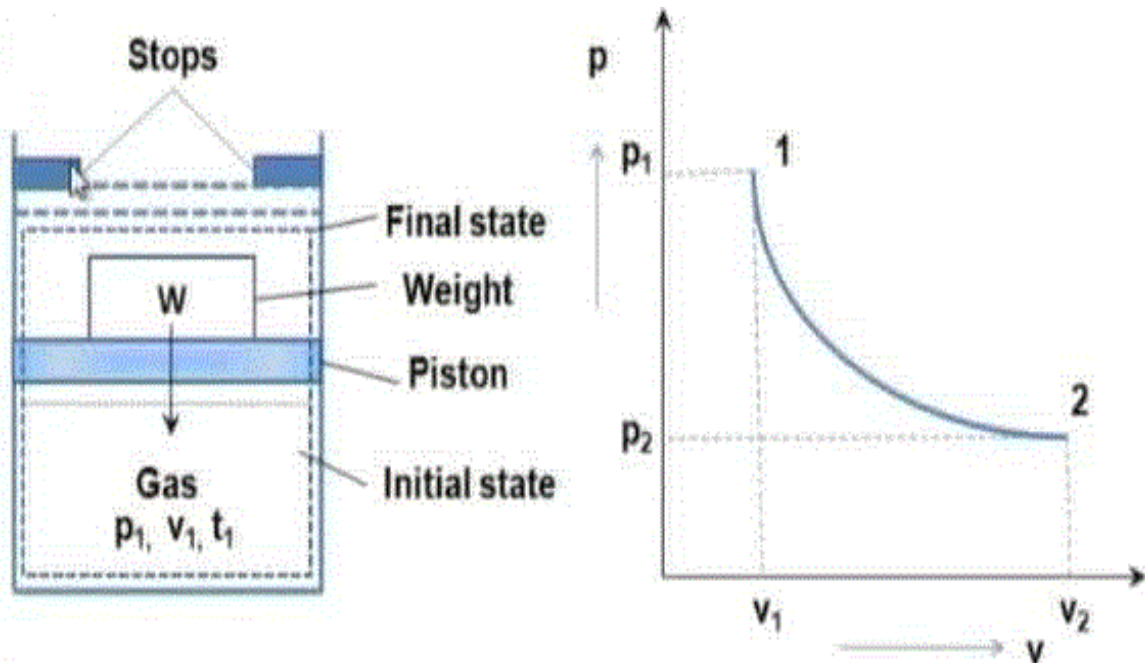

We will see one example for understanding the quasi static process, but let us consider one simple example for better understanding of quasi static process. If a person is coming down from roof to ground floor with the help of ladder steps then it could be considered as quasi static process. But if he jumps from roof to ground floor then it will not be a quasi static process.

Weight placed over the piston is just balancing the force which is exerted in upward direction by gas. If we remove the weight from the piston, system will have unbalanced force and piston will move in upward direction due to force acting over the piston in upward direction by the gas.

Irreversible Process:

The irreversible process is also called the natural process because all the processes occurring in nature are irreversible processes. The natural process occurs due to the finite gradient between the two states of the system. For instance, heat flow between two bodies occurs due to the temperature gradient between the two bodies; this is in fact the natural flow of heat. Similarly, water flows from high level to low level, current moves from high potential

to low potential, etc.

- In the irreversible process the initial state of the system and surroundings cannot be restored from the final state.
- During the irreversible process the various states of the system on the path of change from initial state to final state are not in equilibrium with each other.
- During the irreversible process the entropy of the system increases decisively and it cannot be reduced back to its initial value.
- The phenomenon of a system undergoing irreversible process is called as irreversibility.

Causes of Irreversibility:

Friction: Friction is invariably present in real systems. It causes irreversibility in the process as work done does not show an equivalent rise in the kinetic or potential energy of the system. The fraction of energy wasted due to frictional effects leads to deviation from reversible states.

Free expansion: Free expansion refers to the expansion of unresisted type such as expansion in a vacuum. During this unresisted expansion the work interaction is zero, and without the expense of any work, it is not possible to restore initial states. Thus, free expansion is irreversible.

Heat transfer through a finite temperature difference: Heat transfer occurs only when there exists temperature difference between bodies undergoing heat transfer. During heat transfer, if heat addition is carried out in a finite number of steps then after every step the new state shall be a non-equilibrium state.

Non equilibrium during the process: Irreversibilities are introduced due to lack of thermodynamic equilibrium during the process. Non-equilibrium may be due to mechanical inequilibrium, chemical inequilibrium, thermal inequilibrium, electrical inequilibrium, etc. and irreversibility is called mechanical irreversibility, chemical irreversibility, thermal irreversibility, electrical irreversibility respectively. Factors discussed above are also causing non-equilibrium during the process and therefore make process irreversible.

Heat:

It is the energy in transition between the system and the surroundings by virtue of the difference in temperature Heat is energy transferred from one system to another solely by reason of a temperature difference between the systems. Heat exists only as it crosses the

boundary of a system and the direction of heat transfer is from higher temperature to lower temperature. For thermodynamics sign convention, heat transferred to a system is positive; Heat transferred from a system is negative.

Work:

Thermodynamic definition of work: Positive work is done by a system when the sole effect external to the system could be reduced to the rise of a weight.

Work done by the system is positive and work done on the system is negative.

Types of work interaction:

- Expansion and compression work (displacement work)
- Work of a reversible chemical cell
- Work in stretching of a liquid surface
- Work done on elastic solids
- Work of polarization and magnetization

***pdV*-WORK OR DISPLACEMENT WORK**

Let the gas in the cylinder (Fig. 3.4) be a system having initially the pressure p_1 and volume V_1 . The system is in thermodynamic equilibrium, the state of which is described by the coordinates p_1, V_1 . The piston is

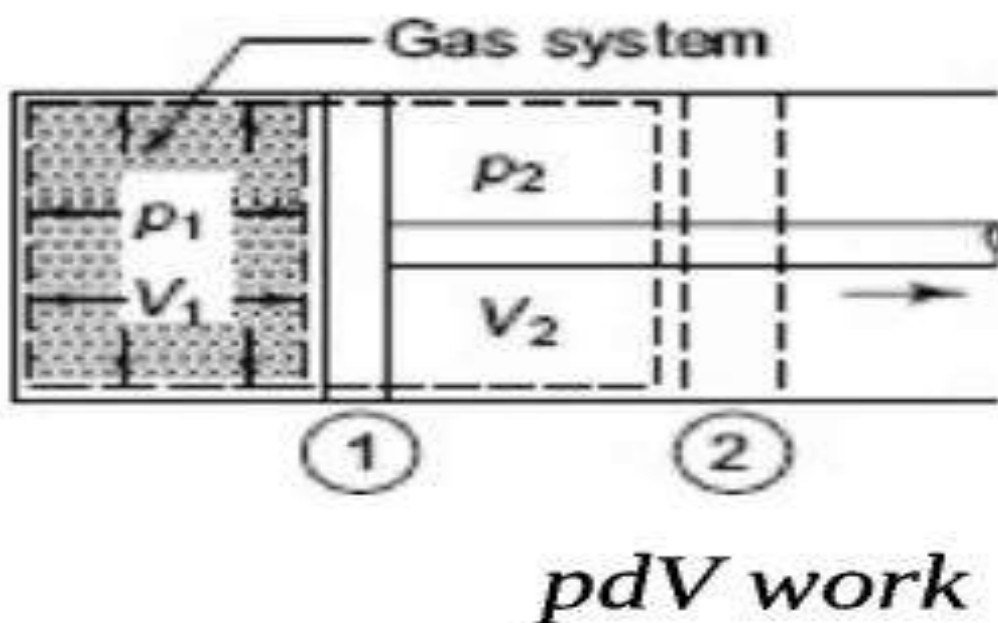

the only boundary which moves due to gas pressure. Let the piston move out to a new final position 2, which is also a thermodynamic equilibrium state specified by pressure p_2 and volume V_2 . At any intermediate point in the travel of the piston, let the pressure be p and the volume V . This must also be an equilibrium state, since macroscopic properties p and V are significant only for equilibrium states. When the piston moves an infinitesimal distance dl , and if 'a' be the area of the piston, the force F acting on the piston $F = p.a$. and the infinitesimal amount of work done by the gas on the piston

$$dW = F \cdot dl = padl = pdV$$

where $dV = a dl =$ infinitesimal displacement volume. The differential sign in dW with the line drawn at the top of it will be explained later.

When the piston moves out from position 1 to position 2 with the volume changing from V_1 to V_2 , the amount of work W done by the system will be

$$W_{-2} = \int_{V_1}^{V_2} pdV$$

The magnitude of the work done is given by the area under the path 1–2, as shown in Fig. 3.5. Since p is at all times a thermodynamic coordinate, all the states passed through by the system as the volume changes from V_1 to V_2 must be equilibrium states, and the path 1–2 *must be quasi-static*. The piston moves infinitely slowly so that every state passed through is an equilibrium state. *The integration $\int pdV$ can be performed only on a quasi-static path.*

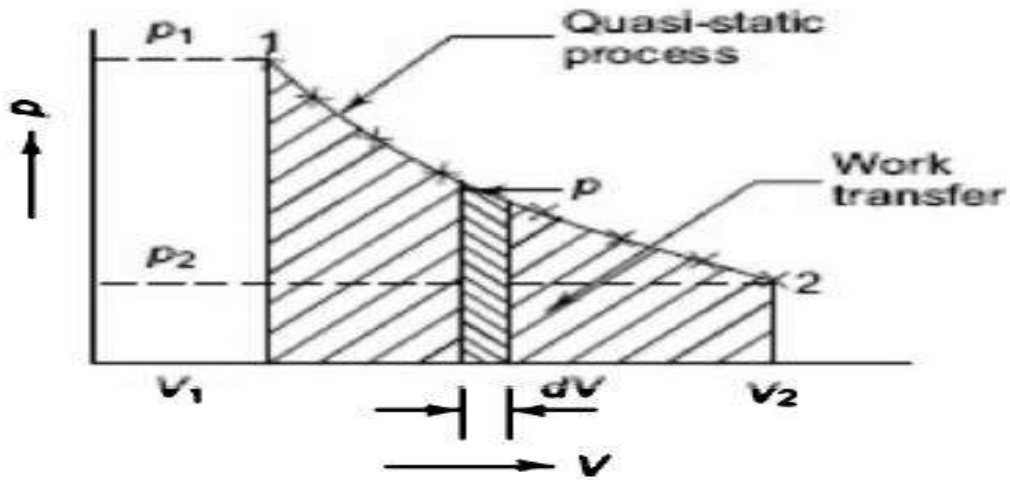

Quasi-static pdV work

2. Shaft work When a shaft, taken as the system (Fig. 3.14a), is rotated by a motor, there is work transfer into the system. This is because the shaft can rotate a pulley which can raise a weight. If T is the torque applied to the shaft and $d\theta$ is the angular displacement of the shaft, the shaft work is

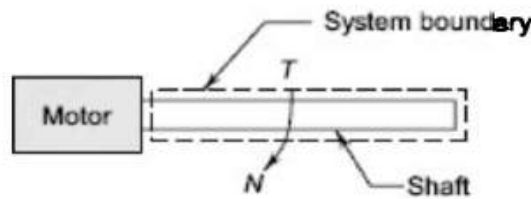

Fig. 3.14(A) Shaft work

$$W = \int_1^2 T d\theta \tag{3.14 a}$$

and the shaft power is

$$W = \int_1^2 T \frac{d\theta}{d\tau} = T\omega \tag{3.15 b}$$

where ω is the angular velocity and T is considered a constant in this

Flow work The flow work, significant only in a flow process or an open system, represents the energy transferred across the system boundary as a result of the energy imparted to the fluid by a pump, blower or compressor to make the fluid flow across the control volume. Flow work is analogous to displacement work. Let p be the fluid pressure in the plane of the imaginary piston, which acts in a direction normal to it (Fig. 3.16). The work done on this imaginary piston by the external pressure as the piston moves forward is given by

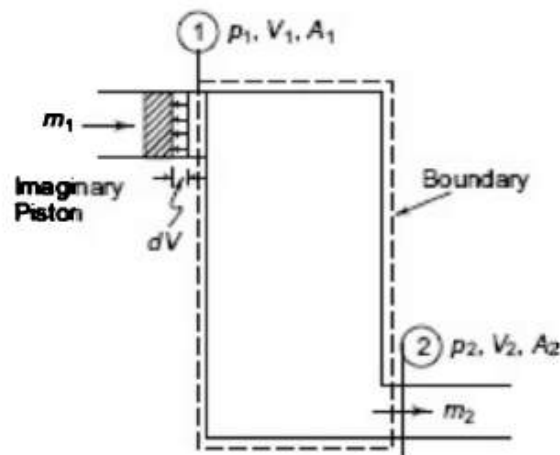

Fig. 3.16 Flow work

$$\delta W_{\text{flow}} = p dV, \quad (3.16)$$

Point and Path functions:

- Point function does not depend on the history (or path) of the system. It only depends on the state of the system.
- Examples of point functions are: temperature, pressure, density, mass, volume, enthalpy, entropy, internal energy etc.
- Path function depends on history of the system (or path by which system arrived at a given state).
- Examples for path functions are work and heat.
- Path functions are not properties of the system, while point functions are properties of the system.
- Change in point function can be obtained by from the initial and final values of the function, whereas path has to defined in order to evaluate path functions.

Zeroth Law of Thermodynamics:

The Thermodynamics Zeroth Law states that if two systems are at the same time in thermal

equilibrium with a third system, they are in equilibrium with each other.

If an object with a higher temperature comes in contact with an object of lower temperature, it will transfer heat to the lower temperature object. The objects will approach the same temperature and in the absence of loss to other objects, they will maintain a single constant temperature. Therefore, thermal equilibrium is attained.

The Zeroth Law

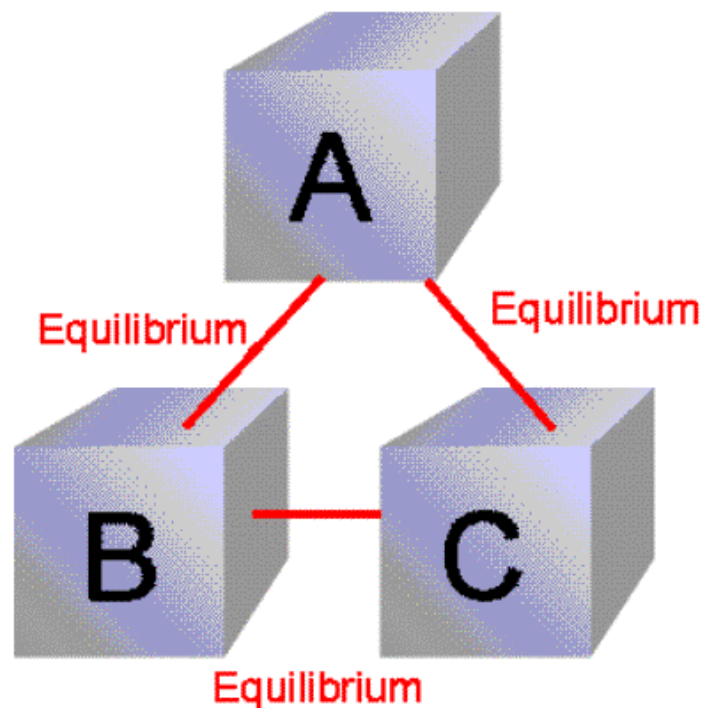

(c) C. Rose-Patruck, Brown University, 7-Jan-99, Chem 201 #1

If objects 'A' and 'C' are in thermal equilibrium with 'B', then object 'A' is in thermal equilibrium with object 'C'. Practically this means all three objects are at the same temperature and it forms the basis for comparison of temperatures.

If $a=b$; $b=c$ then $a=c$

Principles of Thermometry:

Thermometry is the science and practice of temperature measurement. Any measurable change in a thermometric probe (e.g. the dilatation of a liquid in a capillary tube, variation of electrical resistance of a conductor, of refractive index of a transparent material, and so on) can be used to mark temperature levels, that should later be calibrated against an internationally agreed unit if the measure is to be related to other thermodynamic variables.

Thermometry is sometimes split in metrological studies in two subfields: contact thermometry and noncontact thermometry. As there can never be complete thermal uniformity at large, thermometry is always associated to a heat transfer problem with some space-time coordinates of measurement, given rise to time-series plots and temperature maps.

(i) *Constant Volume Gas Thermometers*

This thermometer consists of a capillary tube (C), which connects thermometer bulb with a U-tube manometer. A small amount of helium gas is contained in the bulb 'B'. The left limb of manometer is kept open to atmosphere and can be moved vertically and mercury level on the right limb can be adjusted so that it just touches lip 'L' of the capillary. The pressure of the gas in the bulb is used as a thermometric property and is given by

$$P = P_{atm} + \rho_m h$$

where,

$$P_{atm} = \text{Atmospheric pressure}$$

$$\rho_m = \text{density of mercury}$$

When the bulb is brought in contact with the system whose temperature is to be measured, it comes in thermal equilibrium with the system. The gas in the bulb will be heated and expanded, pushes the mercury column downward on the right limb. This rises mercury column on the left limb. The flexible limb is then adjusted so that the mercury again touches the lip 'L'. The difference in mercury level 'h' is recorded and the pressure 'P' of the gas in the bulb is estimated. Since the gas volume in the bulb is constant, from ideal gas equation we can write,

$$\Delta T = \frac{V}{R} \Delta P \quad (\because PV = mRT)$$

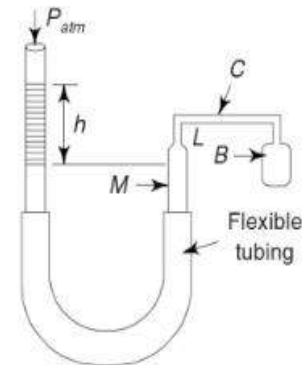
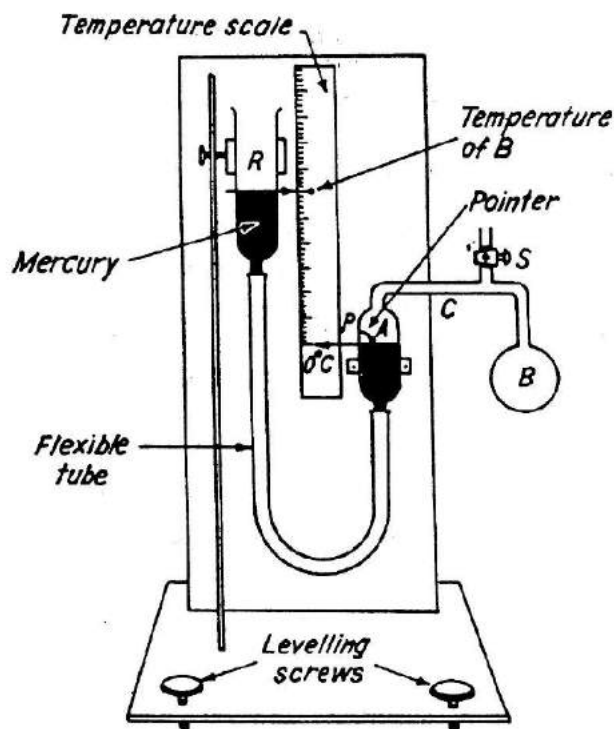

Fig. 1.14 Constant volume gas thermometer



($\because V$ is constant, R is constant)

$$\Delta T \propto \Delta P$$

i.e. the temperature rise is proportional to pressure rise.

Since for an ideal gas at constant volume, $T \propto P$

$$\frac{T}{T_{tp}} = \frac{P}{P_{tp}}$$

$$T = 273.16 \frac{P}{P_{tp}}$$

T_{tp} : Triple point temperature of water

or

$$T = 273.16 \lim_{P_{tp} \rightarrow 0} \left[\frac{P}{P_{tp}} \right]$$

Scales of Temperature:

There are three temperature scales in use Fahrenheit, Celsius and Kelvin. Fahrenheit temperature scale is a scale based on 32 for the freezing point of water and 212 for the boiling point of water, the interval between the two being divided into 180 parts.

The conversion formula for a temperature that is expressed on the Celsius (C) scale to its Fahrenheit (F) representation is: $F = 9/5C + 32$.

Celsius temperature scale also called centigrade temperature scale, is the scale based on 0 for the freezing point of water and 100 for the boiling point of water.

Kelvin temperature scale is the base unit of thermodynamic temperature measurement in the International System (SI) of measurement. It is defined as $1/273.16$ of the triple point (equilibrium among the solid, liquid, and gaseous phases) of pure water.

Joule's experiment:

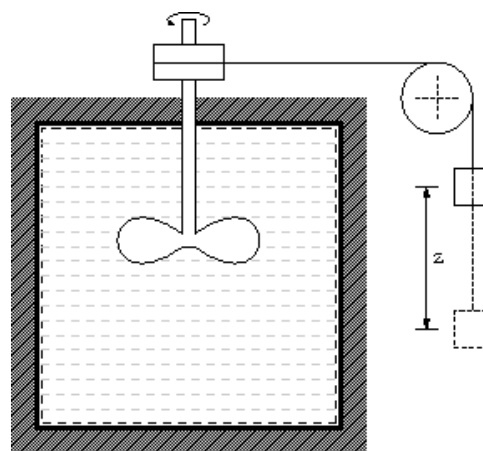

James P. Joule carried out his famous experiment; he placed known amounts of water, oil, and mercury in an insulated container and agitated the fluid with a rotating stirrer. The amounts of work done on the fluid by the stirrer were accurately measured, and the temperature changes of the fluid were carefully noted. He found for each fluid that a fixed amount of work was required per unit mass for every degree of temperature rise caused by the stirring, and that the original temperature of the fluid could be restored by the transfer of heat through simple contact with a cooler object. In this experiment you can conclude there is a relationship between heat and work or in other word heat is a form of energy.

Internal Energy

Through, Joule experiment what happen to energy between time it is added to water as work, and time it is extracted to heat? Logic suggests that this energy contained in the water in another form which called internal energy.

Internal energy refers to energy of molecules of substance which are ceaseless motion and possess kinetics energy. The addition of heat to a substance increases this molecular activity, and thus causes an increase in its internal energy. Work done on the substance can have the same effect, as was shown by Joule. Internal energy cannot be directly measured; there are no internal-energy meters. As a result, absolute values are unknown. However, this is not a disadvantage in thermodynamic analysis, because only changes in internal energy are required.

First Law of Thermodynamics:

During a thermodynamic cycle, a cyclic process the systems undergoes, the cyclic integral of heat added is equal to integral of work done. The first law equation can also be written in the form,

$$\oint(dQ - dW) = 0$$

Equation $dU = dQ - dW$ is a corollary to the first law of thermodynamics. It shows that there exists a property internal energy (U) of the system, such that a change in its value is equal to the difference in heat entering and work leaving the system.

The First law of thermodynamics states that energy is neither created nor destroyed. Thus the total energy of the universe is a constant. However, energy can certainly be transferred from one form to another form.

The 1st law of thermodynamics can be mathematically stated as follows:

$$\oint dQ = \oint dW$$

Corollary 1:

There exists property of closed system; the change in value of this property during the process is given by the difference between heat supplied and work done.

$$dU = dQ - dW$$

Here E is property of system and is called as total energy that includes internal energy, kinetic energy, potential energy, electrical energy, magnetic energy, chemical energy, etc.

Corollary 2:

For the isolated system, heat and work both interactions are absent ($dQ = 0$, $dW = 0$) and $E = \text{constant}$. Energy can neither be created nor be destroyed; but, it can be converted from one form to other.

Corollary 3:

A perpetual motion machine of first kind is almost impossible.

Perpetual Motion Machine of First Kind (PMM1):

A hypothetical machine which can produce useful work *without any source* or which can produce more energy than consumed. It violates the first law of Thermodynamics. Perpetual Motion Machine 1 (PMM1) is a machine that violates first law of thermodynamics. First law of thermodynamics states that energy can be neither created or nor destroyed. A perpetual motion machine 1 violates the law by creating energy. All processes in universe comply with first and second law of thermodynamics. Therefore PMM1 does not and can never exist.

e.g.: An electric heater that consumes 1KW of electricity cannot produce more than 1KW heat.

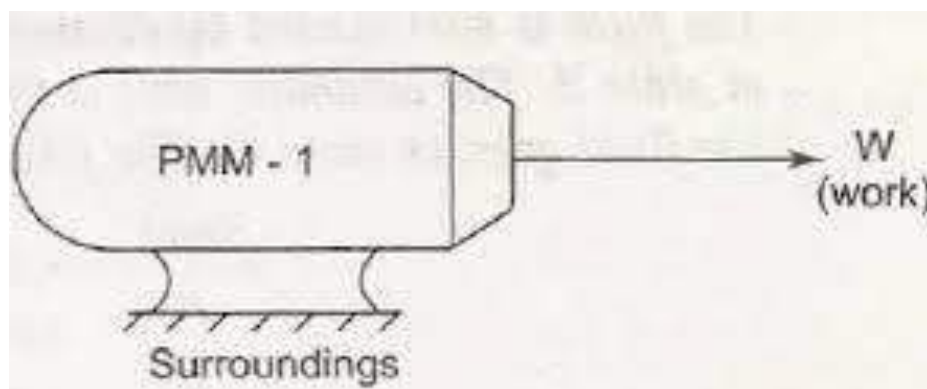

First law applied to a flow process**Steady flow energy equation:**

Virtually all the practical systems involve flow of mass across the boundary separating the system and the surroundings. Whether it be a steam turbine or a gas turbine or a compressor or an automobile engine there exists flow of gases/gas mixtures into and out of the system. So we must know how the first Law of thermodynamics can be applied to an open system.

The fluid entering the system will have its own internal, kinetic and potential energies.

Let u_1 be the specific internal energy of the fluid entering C_1 be the velocity of the fluid while entering Z_1 be the potential energy of the fluid while entering Similarly let u_2 , C_2 and Z_2 be respective entities while leaving.

APPLICATION OF FIRST LAW TO STEADY FLOW PROCESS**Steady Flow Energy Equation (S.F.E.E.)**

In many practical problems, the rate at which the fluid flows through a machine or piece of apparatus is constant. This type of flow is called *steady flow*.

Assumptions :

The following *assumptions* are made in the system analysis :

- (i) The mass flow through the system remains constant.
- (ii) Fluid is uniform in composition.
- (iii) The only interaction between the system and surroundings are work and heat.
- (iv) The state of fluid at any point remains constant with time.
- (v) In the analysis only potential, kinetic and flow energies are considered.

Fig. 4.30 shows a schematic flow process for an open system. An open system is one in which both mass and energy may cross the boundaries. A wide interchange of energy may take place within an open system. Let the system be an automatic engine with the inlet manifold at the first state point and exhaust pipe as the second point. There would be an interchange of chemical energy in the fuel, kinetic energy of moving particles, internal energy of gas and heat transferred and shaft work within the system. From Fig. 4.30 it is obvious that if there is no variation of flow of mass or energy with time across the boundaries of the system the steady flow will prevail. The conditions may pass through the cyclic or non-cyclic changes within the system. As a result the mass entering the system equals the mass leaving, also energy entering the system equals energy leaving.

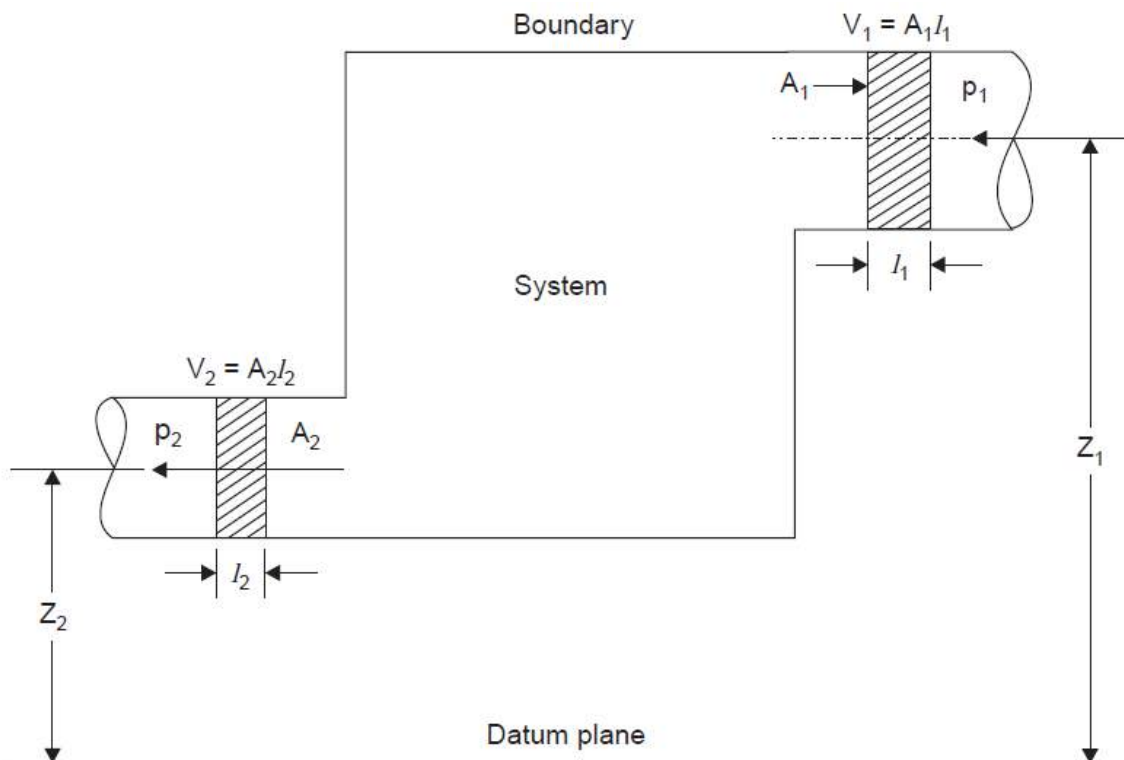

Fig. 4.30

The steady flow equation can be expressed as follows :

$$u_1 + \frac{C_1^2}{2} + Z_1g + p_1v_1 + Q = u_2 + \frac{C_2^2}{2} + Z_2g + p_2v_2 + W \quad \dots(4.45)$$

$$(u_1 + p_1v_1) + \frac{C_1^2}{2} + Z_1g + Q = (u_2 + p_2v_2) + \frac{C_2^2}{2} + Z_2g + W$$

$$h_1 + \frac{C_1^2}{2} + Z_1g + Q = h_2 + \frac{C_2^2}{2} + Z_2g + W \quad [\because h = u + pv]$$

If Z_1 and Z_2 are neglected, we get

$$h_1 + \frac{C_1^2}{2} + Q = h_2 + \frac{C_2^2}{2} + W \quad \dots[4.45 (a)]$$

where, Q = Heat supplied (or entering the boundary) per kg of fluid,
 W = Work done by (or work coming out of the boundary) 1 kg of fluid,

C = Velocity of fluid ,
 Z = Height above datum,
 p = Pressure of the fluid,
 u = Internal energy per kg of fluid, and
 pv = Energy required for 1 kg of fluid.

This equation is applicable to any medium in any steady flow. It is applicable not only to rotary machines such as centrifugal fans, pumps and compressors but also to reciprocating machines such as steam engines.

ENGINEERING APPLICATIONS OF STEADY FLOW ENERGY EQUATION (S.F.E.E.)

. Water Turbine

Refer to Fig. 4.32. In a water turbine, water is supplied from a height. The potential energy of water is converted into kinetic energy when it enters into the turbine and part of it is converted into useful work which is used to generate electricity.

Considering centre of turbine shaft as *datum*, the energy equation can be written as follows :

$$\left(u_1 + p_1 v_1 + Z_1 g + \frac{C_1^2}{2} \right) + Q = \left(u_2 + p_2 v_2 + Z_2 g + \frac{C_2^2}{2} \right) + W$$

In this case,

$$Q = 0$$

$$\Delta u = u_2 - u_1 = 0$$

∴

$$v_1 = v_2 = v$$

$$Z_2 = 0$$

$$\left(p_1 v + Z_1 g + \frac{C_1^2}{2} \right) = \left(p_2 v + Z_2 g + \frac{C_2^2}{2} \right) + W$$

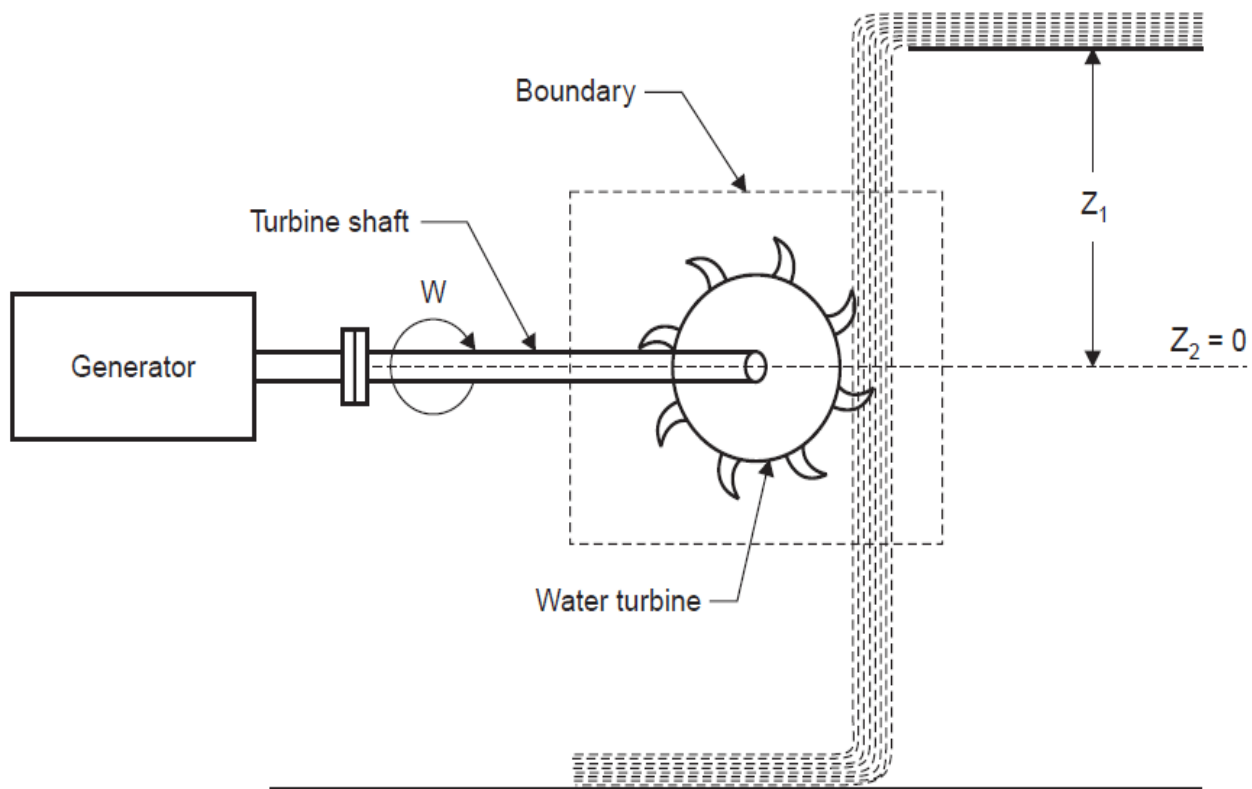

Fig. 4.32. Water turbine.

Steam or Gas Turbine

In a steam or gas turbine steam or gas is passed through the turbine and part of its energy is converted into work in the turbine. This output of the turbine runs a generator to produce electricity as shown in Fig. 4.33. The steam or gas leaves the turbine at lower pressure or temperature.

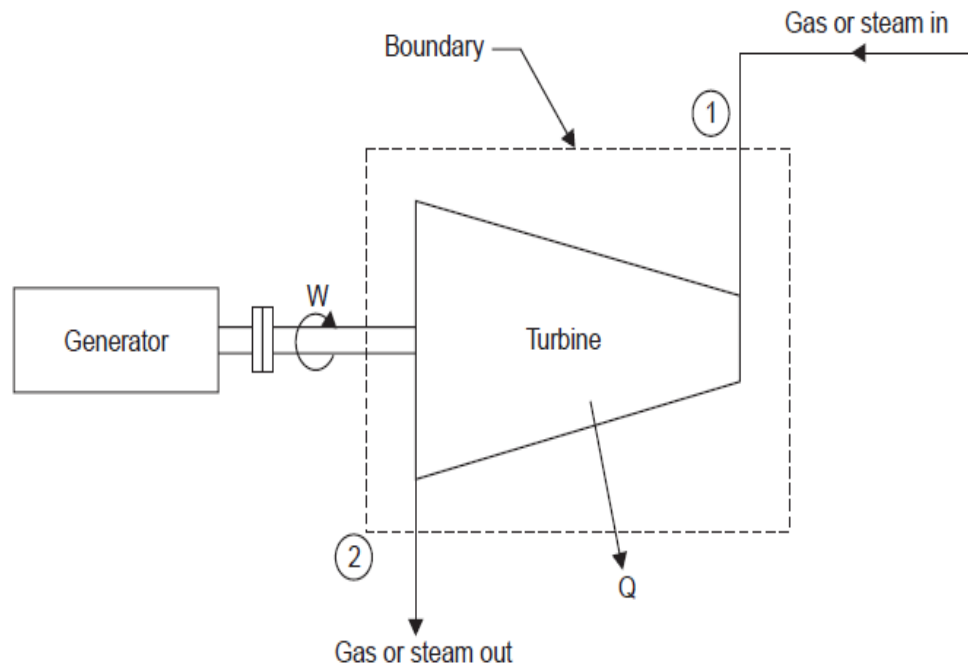

Fig. 4.33. Steam or gas turbine.

Applying energy equation to the system.

Here, $Z_1 = Z_2$ (i.e., $\Delta Z = 0$)

$$h_1 + \frac{C_1^2}{2} - Q = h_2 + \frac{C_2^2}{2} + W \quad \dots(4.55)$$

The sign of Q is *negative* because heat is *rejected* (or comes out of the boundary).

The sign of W is *positive* because work is done by the system (or work comes out of the boundary).

Reciprocating Compressor

Refer Fig. 4.36. The reciprocating compressor draws in air from atmosphere and supplies at a considerable higher pressure in small quantities (compared with centrifugal compressor). The reciprocating compressor can be considered as steady flow system *provided the control volume includes the receiver which reduces the fluctuations of flow considerably.*

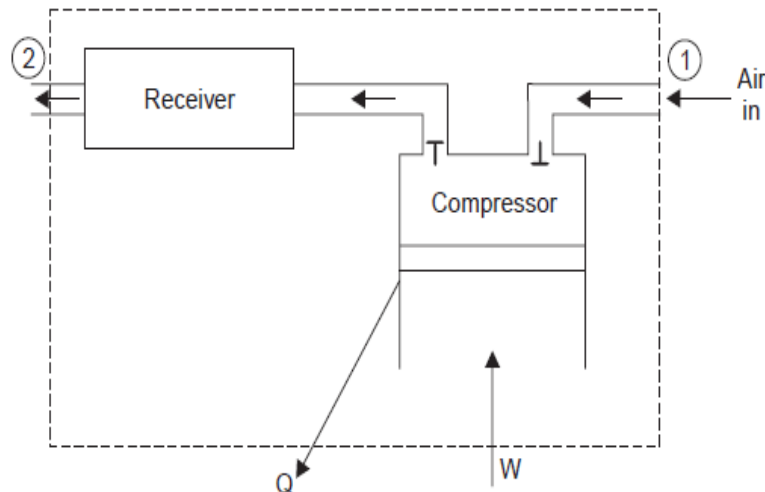

Fig. 4.36. Reciprocating compressor.

Applying energy equation to the system, we have :

$\Delta PE = 0$ and $\Delta KE = 0$ since these changes are negligible compared with other energies.

$$\therefore h_1 - Q = h_2 - W \quad \dots(4.58)$$

Boiler

A boiler transfers heat to the incoming water and generates the steam. The system is shown in Fig. 4.37.

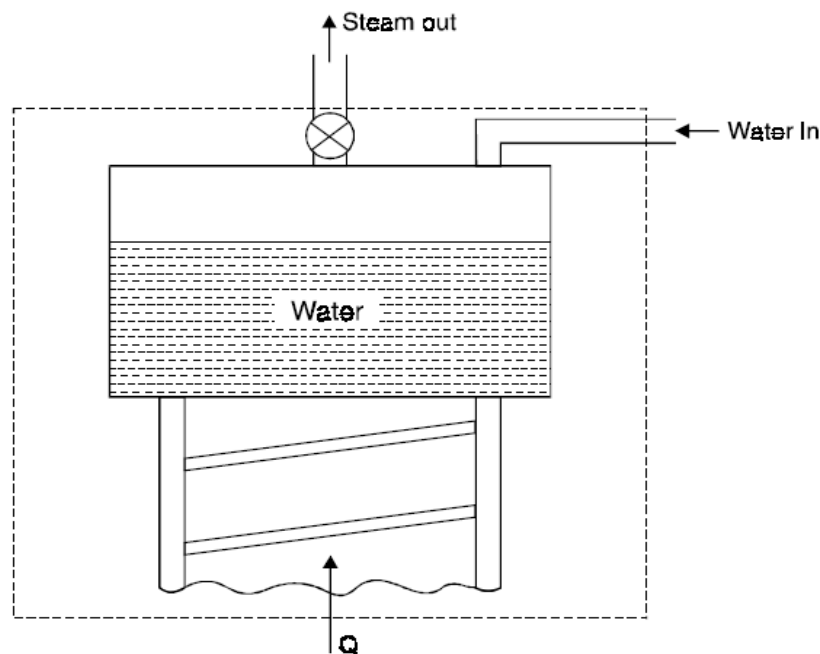

Fig. 4.37 Boiler

For this system, $\Delta Z = 0$ and $\Delta \left(\frac{C_2^2}{2} \right) = 0$

$W = 0$ since neither any work is developed nor absorbed.

Applying energy equation to the system

$$h_1 + Q = h_2$$

∴ Steam Nozzle

In case of a nozzle as the enthalpy of the fluid decreases and pressure drops simultaneously the flow of fluid is *accelerated*. This is generally used to convert the part of the energy of steam into *kinetic energy of steam* supplied to the turbine.

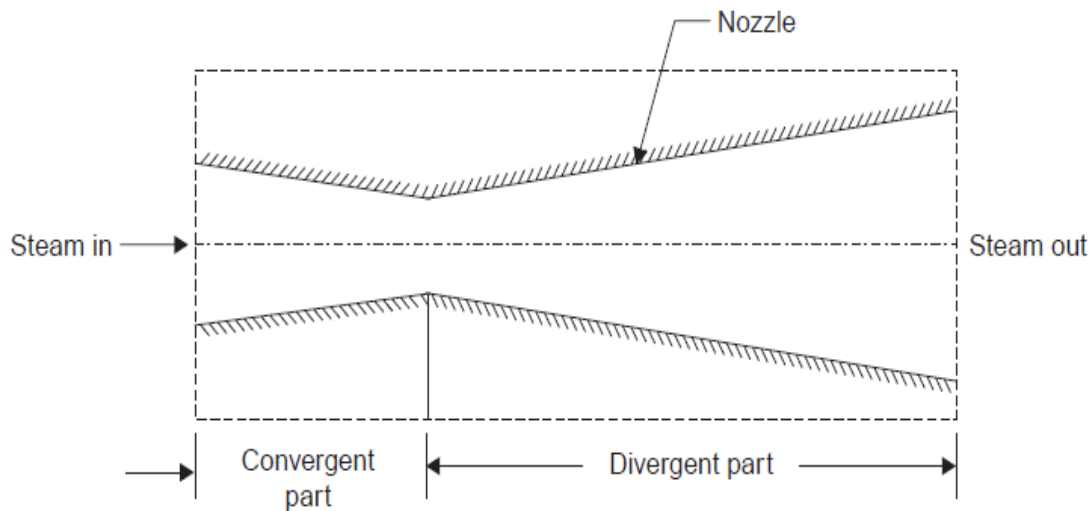

Fig. 4.40. Steam nozzle.

Fig. 4.40 shows a commonly used convergent-divergent nozzle.

For this system,

$$\Delta PE = 0$$

$$W = 0$$

$$Q = 0$$

Applying the energy equation to the system,

$$h_1 + \frac{C_1^2}{2} = h_2 + \frac{C_2^2}{2}$$

$$\text{or} \quad \frac{C_2^2}{2} - \frac{C_1^2}{2} = h_1 - h_2 \quad \text{or} \quad C_2^2 - C_1^2 = 2(h_1 - h_2)$$

$$\text{or} \quad C_2^2 = C_1^2 + 2(h_1 - h_2)$$

$$\therefore C_2 = \sqrt{C_1^2 + 2(h_1 - h_2)}$$

where velocity C is in m/s and enthalpy h in joules.

If $C_1 \ll C_2$, then

$$C_2 = \sqrt{2(h_1 - h_2)}$$

$$\therefore C_2 = \sqrt{2\Delta h}$$

Example 4.1 A stationary mass of gas is compressed without friction from an initial state of 0.3 m^3 and 0.105 MPa to a final state of 0.15 m^3 and 0.105 MPa , the pressure remaining constant during the process. There is a transfer of 37.6 kJ of heat from the gas during the process. How much does the internal energy of the gas change?

Solution First law for a stationary system in a process gives

$$Q = \Delta U + W$$

or
$$Q_{1-2} = U_2 - U_1 + W_{1-2} \quad (1)$$

Here
$$W_{1-2} = \int_{V_1}^{V_2} p dV = p(V_2 - V_1)$$

$$= 0.105 (0.15 - 0.30) \text{ MJ} = -15.75 \text{ kJ}$$

$$Q_{1-2} = -37.6 \text{ kJ}$$

\therefore Substituting in Eq. (1)

$$-37.6 \text{ kJ} = U_2 - U_1 - 15.75 \text{ kJ}$$

\therefore
$$U_2 - U_1 = -21.85 \text{ kJ}$$

The internal energy of the gas decreases by 21.85 kJ in the process.

A system undergoes a process 1–2 in which it absorbs 200 kJ energy as heat while it does 100 kJ of work. Then it follows the path 2–3 in which it rejects 50 kJ energy as heat, when 80 kJ work is done on it. If it is required to restore the system to state-1 through an adiabatic path, calculate the work and heat interactions along the adiabatic. Also calculate the net work and heat interactions.

Solution: Application of the first law of thermodynamics to the process 1–2 gives

$$U_2 - U_1 = Q_{12} - W_{12}$$

$$= 200 - 100 = 100 \text{ kJ}$$

Similarly
$$U_3 - U_2 = Q_{23} - W_{23}$$

$$= -50 - (-80) = 30 \text{ kJ}$$

For the complete cycle, $\Delta U = 0$

or
$$(U_2 - U_1) + (U_3 - U_2) + (U_1 - U_3) = 0$$

or $100 + 30 + (U_1 - U_3) = 0$

or $U_1 - U_3 = -130 \text{ kJ}$

The process 3-1 is desired to be adiabatic. Therefore $Q_{31} = 0$. **Ans.**

The first law of thermodynamics for the process 3-1 gives

$$U_1 - U_3 = Q_{31} - W_{31}$$

or $-130 = 0 - W_{31}$

Therefore, work done during adiabatic process = 130 kJ **Ans.**

Net work is given by

$$\begin{aligned} W_{\text{net}} &= \oint \delta W \\ &= W_{12} + W_{23} + W_{31} \\ &= 100 + (-80) + 130 = 150 \text{ kJ} \end{aligned} \quad \text{Ans.}$$

We know that for a cyclic process

$$\oint \delta Q = \oint \delta W = 150 \text{ kJ}$$

Therefore, net heat interaction = 150 kJ **Ans.**

Example 4.2 When a system is taken from state *a* to state *b*, in Fig. 4.10 along path *acb*, 84 kJ of heat flow into the system, and the system does 32 kJ of work. (a) How much will the heat that flows into the system along path *adb* be, if the work done is 10.5 kJ? (b) When the system is returned from *b* to *a* along the curved path, the work done on the system is 21 kJ. Does the system absorb or liberate heat, and how much of the heat is absorbed or liberated? (c) If $U_a = 0$ and $U_d = 42 \text{ kJ}$, find the heat absorbed in the processes *ad* and *db*.

Solution

$$Q_{acb} = 84 \text{ kJ}$$

$$W_{acb} = 32 \text{ kJ}$$

We have

$$Q_{acb} = U_b - U_a + W_{acb}$$

$$\therefore U_b - U_a = 84 - 32 = 52 \text{ kJ}$$

(a) $Q_{adb} = U_b - U_a + W_{adb}$
 $= 52 + 10.5 = 62.5 \text{ kJ}$

(b) $Q_{b-a} = U_a - U_b + W_{b-a}$
 $= -52 - 21 = -73 \text{ kJ}$

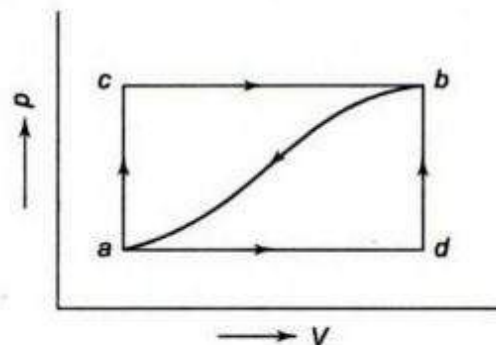

Fig. 4.10

The system liberates 73 kJ of heat

$$(c) \quad W_{adb} = W_{ad} + W_{db} = W_{ad} = 10.5 \text{ kJ}$$

$$\begin{aligned} \therefore \quad Q_{ad} &= U_d - U_a + W_{ad} \\ &= 42 - 0 + 10.5 = 52.5 \text{ kJ} \end{aligned}$$

$$\text{Now} \quad Q_{adb} = 62.5 \text{ kJ} = Q_{ad} + Q_{db}$$

$$\therefore \quad Q_{db} = 62.5 - 52.5 = \mathbf{10 \text{ kJ}}$$

Example 4.3 A piston and cylinder machine contains a fluid system which passes through a complete cycle of four processes. During a cycle, the sum of all heat transfers is -170 kJ . The system completes 100 cycles per min. Complete the following table showing the method for each item, and compute the net rate of work output in kW.

Process	Q (kJ/min)	W (kJ/min)	ΔE (kJ/min)
$a-b$	0	2,170	—
$b-c$	21,000	0	—
$c-d$	-2,100	—	-36,600
$d-a$	—	—	—

Solution Process $a-b$:

$$Q = \Delta E + W$$

$$0 = \Delta E + 2170$$

$$\therefore \quad \Delta E = -2170 \text{ kJ/min}$$

Process $b-c$:

$$Q = \Delta E + W$$

$$21,000 = \Delta E + 0$$

$$\therefore \quad \Delta E = 21,000 \text{ kJ/min}$$

Process $c-d$:

$$Q = \Delta E + W$$

$$-2100 = -36,600 + W$$

$$\therefore W = 34,500 \text{ kJ/min}$$

Process $d-a$:

$$\sum_{\text{cycle}} Q = -170 \text{ kJ}$$

The system completes 100 cycles/min.

$$\therefore Q_{ab} + Q_{bc} + Q_{cd} + Q_{da} = -17,000 \text{ kJ/min}$$

$$0 + 21,000 - 2100 + Q_{da} = -17,000$$

$$\therefore Q_{da} = -35,900 \text{ kJ/min}$$

Now $\oint dE = 0$, since cyclic integral of any property is zero.

$$\therefore \Delta E_{a-b} + \Delta E_{b-c} + \Delta E_{c-d} + \Delta E_{d-a} = 0$$

$$-2170 + 21,000 - 36,600 + \Delta E_{d-a} = 0$$

$$\therefore \Delta E_{d-a} = 17,770 \text{ kJ/min}$$

$$\therefore W_{d-a} = Q_{d-a} - \Delta E_{d-a}$$

$$= -35,900 - 17,770 = -53,670 \text{ kJ/min}$$

The table becomes

Process	Q (kJ/min)	W (kJ/min)	ΔE (kJ/min)
$a-b$	0	2170	-2170
$b-c$	21,000	0	21,000
$c-d$	-2100	34,500	-36,600
$d-a$	-35,900	-53,670	17,770

$$\text{Since } \sum_{\text{cycle}} Q = \sum_{\text{cycle}} W$$

Rate of work output

$$= -17,000 \text{ kJ/min} = -283.3 \text{ kW}$$

A system receives 0.7 kg/s of a fluid at a velocity of 40 m/s at an elevation of 25 m. At the exit, at an elevation of 50 m, the fluid leaves at a velocity of 10 m/s. The specific enthalpies of entering and leaving fluids are 2700 kJ/kg and 2900 kJ/kg respectively. If the work done by the system is 5 kW, determine the heat transformation.

Solution: Given: $\dot{m}_1 = \dot{m}_2 = \dot{m} = 0.7 \text{ kg/s}$, $V_1 = 40 \text{ m/s}$, $z_1 = 25 \text{ m}$, $h_1 = 2700 \text{ kJ/kg}$,

$$V_2 = 10 \text{ m/s}, z_2 = 50 \text{ m}, h_2 = 2900 \text{ kJ/kg}$$

Then

$$W_{12} = 5 \text{ kW} = 5 \text{ kJ/s}$$

Therefore,

$$w = \frac{W_{12}}{\dot{m}} = \frac{5}{0.7} = 7.143 \text{ kJ/kg}$$

We know that the steady state steady flow energy equation for $\dot{m}_1 = \dot{m}_2$ is:

$$q + h_1 + \frac{V_1^2}{2} + gz_1 = h_2 + \frac{V_2^2}{2} + gz_2 + w$$

Therefore,

$$\begin{aligned} q &= (h_2 - h_1) + \left(\frac{V_2^2 - V_1^2}{2} \right) + (z_2 - z_1)g + w \\ &= (2900 - 2700) + \left(\frac{10^2 - 40^2}{2} \right) \times 10^{-3} + (50 - 25) \times 9.81 \times 10^{-3} + 7.143 \\ &= 206.64 \text{ kJ/kg} \end{aligned}$$

Total heat transferred = $206.64 \times 0.7 = 144.65 \text{ kW}$ **Ans.**

Industry applications

- Automobile industries.
- Refrigeration industries
- Air craft applications
- Defense industries
- Thermal power plants etc.

Assignment questions:

1. What is meant by thermodynamic equilibrium? Explain with the help of examples.
2. What is meant by SFEE and derive it and reduce it for the turbine.
3. Write about constant volume gas Thermometer? Why it is preferred over a constant pressure gas Thermometer.
4. A blower handles 1kg/s of air at 20°C and consuming a power of 15 kw. The inlet and outlet velocities of air are 100 m/s and 150 m/s respectively. Find the exit air temperature, assuming adiabatic conditions. Take C_p of air as 1.005 kJ/kgk.
5. Distinguish between macroscopic and microscopic point of view?
6. Discuss Quasi Static process, what are its characteristics?
7. Discuss First law of thermodynamics, explain Joule's experiment.

Tutorial Questions

1. A piston cylinder device operates 1kg of fluid at 20atm pressure with initial volume is 0.04m³. Fluid is allowed to expand reversibly following $pV^{1.45}=C$. So that the volume becomes double. The fluid is cooled at constant pressure until the piston comes back. Determine the work done in each process?
2. When a stationary mass of gas was compressed without friction at constant pressure, its initial state of 0.4m³ and 0.105MPa was found to change to final state of 0.20m³ and 0.105MPa. There was a transfer of 42.5kJ of heat from the gas during the process. Determine the change in internal energy of the gas?
3. 0.44kg of air at 1800C, expands adiabatically to 3times its original volume and during the process there is a fall in temperature to 150C. The work done during the process is 52.5kJ. Calculate C_p and C_v ?

4. A new scale N of temperature is divided in such a way that the freezing point of ice is 1000N and the boiling point is 4000N. What is the temperature reading on this new scale when the temperature is 1500C? At what temperature both the Celsius and the new scale reading would be the same?
5. A piston-cylinder device operates 1 kg of fluid at 20 atm. Pressure. The initial volume is 0.04 m³. The fluid is allowed to expand reversibly following a process $pV^{1.4} = \text{constant}$ so that the volume becomes double. The fluid is then cooled at a constant pressure until the piston comes back to the original position. Keeping the piston unaltered, heat is added reversibly to restore it to the initial pressure. Calculate the work done in the cycle.

A Piston and cylinder machine contains a fluid system which passes through a complete cycle of four processes. During a cycle the sum of all heat transfers is -170kJ. The system completes 100cycles/minute. Complete the following table showing the method for each item and **compute** net rate of work output in kW.

Process	Q(kJ/min)	W(kJ/min)	$\Delta E(\text{kJ/min})$
a-b	0	2170	----
b-c	21000	0	----
c-d	-2100	----	-36600
d-a	----	----	----

6. A fluid is confined in a cylinder by a spring loaded friction less piston, so

UNIT- II

Entropy

Limitations of the First Law:

- First law does not provide a clear idea about the direction of absorption or evolution of heat.
- The first law of thermodynamics merely indicates that in any process there is a transformation between the various forms of energy involved in the process but provides no information regarding the feasibility of such transformation.
- First law does not provide any information regarding the direction processes will take whether it is a spontaneous or a non spontaneous process.

Thermal Reservoir:

A thermal reservoir is a large system (very high mass \times specific heat value) from which a quantity of energy can be absorbed or added as heat without changing its temperature. The atmosphere and sea are examples of thermal reservoirs. Any physical body whose thermal energy capacity is large relative to the amount of energy it supplies or absorbs can be modelled as a thermal reservoir. A reservoir that supplies energy in the form of heat is called a source and one that absorbs energy in the form of heat is called a sink.

Heat Engine:

It is a cyclically operating device which absorbs energy as heat from a high temperature reservoir, converts part of the energy into work and rejects the rest of the energy as heat to a thermal reservoir at low temperature.

The working fluid is a substance, which absorbs energy as heat from a source, and rejects energy as heat to a sink.

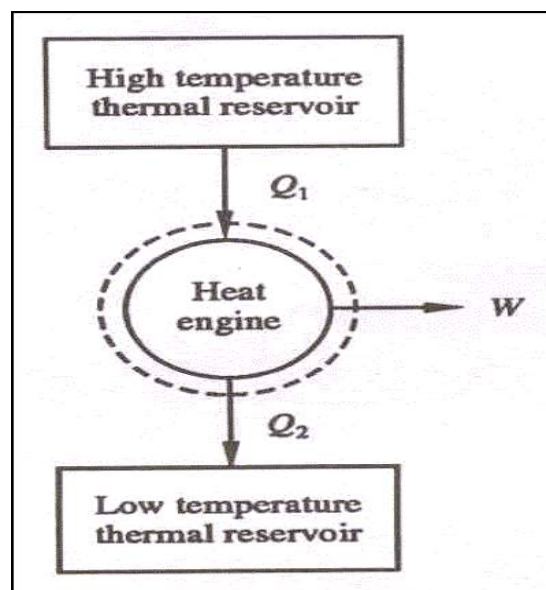

Schematic representation of Heat Engine

Parameters of performance**The efficiency of Heat Engine**

The efficiency ' η ' of the heat engine is the ratio between its output of work to the heat supply of the heat engine. Let us derive an expression for the efficiency of a heat engine.

$$\eta = W/Q_1$$

where, W is the work done by the engine and Q_1 is the heat absorbed from the source. After each cycle, the engine returns to its original state so that it does not affect its internal energy.

$$\Delta U = 0$$

$$W = Q_1 - Q_2$$

Hence the engine efficiency is:

$$\eta = (Q_1 - Q_2)/Q_1$$

$$\eta = 1 - Q_2/Q_1$$

So here efficiency will be 100% but in actual, this is not possible because there will be some loss of energy in the system. Hence for every engine, there is a limit for its efficiency. Gasoline and diesel engines, jet engines, and steam turbines that generate electricity are all examples of heat engines.

Heat pump:

A heat pump is a device that transfers heat energy from a source of heat to what is called a heat sink. Heat pumps move thermal energy in the opposite direction of spontaneous heat transfer, by absorbing heat from a cold space and releasing it to a warmer one. A heat pump uses a small amount of external power to accomplish the work of transferring energy from the heat source to the heat sink. The most common design of a heat pump involves four main components – a condenser, an expansion valve, an evaporator and a compressor. The heat transfer medium circulated through these components is called refrigerant.

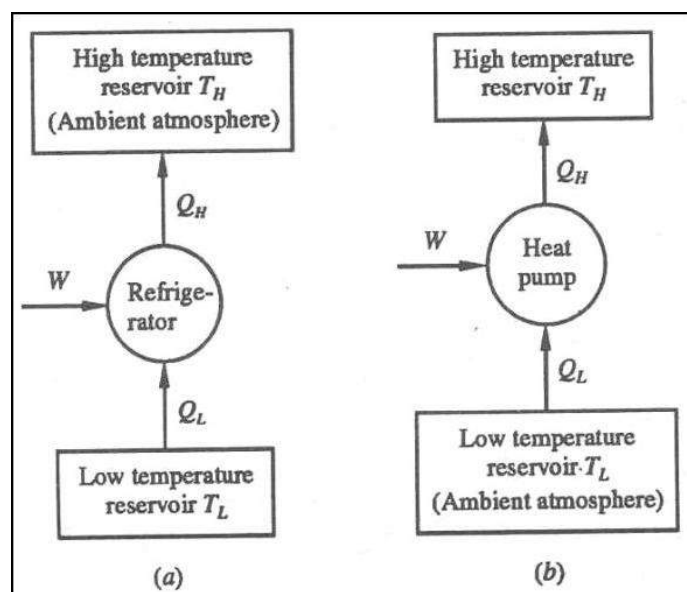
**Schematic representation of Heat Pump Coefficient of Performance**

The coefficient of performance, COP, of a refrigerator is defined as the heat removed from the cold reservoir Q_{cold} , (i.e. inside a refrigerator) divided by the work W done to remove the heat (i.e. the work done by the compressor).

Coefficient of Performance of a Refrigerator and a Heat Pump

The coefficient of performance for cooling of a refrigerator, and for heating of a heat pump can now be expressed as

$$COP_C = \frac{Q_L}{W} = \frac{Q_L}{Q_H - Q_L} = \frac{1}{\frac{Q_H}{Q_L} - 1}$$

$$COP_H = \frac{Q_H}{W} = \frac{Q_H}{Q_H - Q_L} = \frac{1}{1 - \frac{Q_L}{Q_H}}$$

It is seen that, since W is finite, both COP_C and COP_H are less than ∞ .

Also, from the first law equation, since $Q_H = Q_L + W$

$$\frac{Q_H}{W} = \frac{Q_L}{W} + 1$$

$$COP_H = COP_C + 1$$

Accordingly, COP_H is always greater than unity. It is so since Q_H is always greater than Q_L by the amount W .

COP - coefficient of performance - equation

As can be seen, the better (more efficient) the refrigerator is when more heat Q_{cold} can be removed from the inside of the refrigerator for a given amount of work. Since the first law of thermodynamics must be valid also in this case ($Q_{\text{cold}} + W = Q_{\text{hot}}$), we can rewrite the above equation:

The COP for heating and cooling are thus different, because the heat reservoir of interest is different. When one is interested in how well a machine cools, the COP is the ratio of the heat removed from the cold reservoir to input work. However, for heating, the COP is the ratio of the heat removed from the cold reservoir plus the input work to the input work: medium to a high-temperature is called heat pump.

Second Law of Thermodynamics

The second law of thermodynamics is a general principle which places constraints upon the direction of heat transfer and the attainable efficiencies of heat engines. In so doing, it goes beyond the limitations imposed by the first law of thermodynamics.

Kelvin-Planck Statement:

It is impossible to devise a cyclically operating device, which produces no other effect than the

extraction of heat from a single thermal reservoir and delivers an equivalent amount of work. Heat engine with single thermal reservoir is not possible.

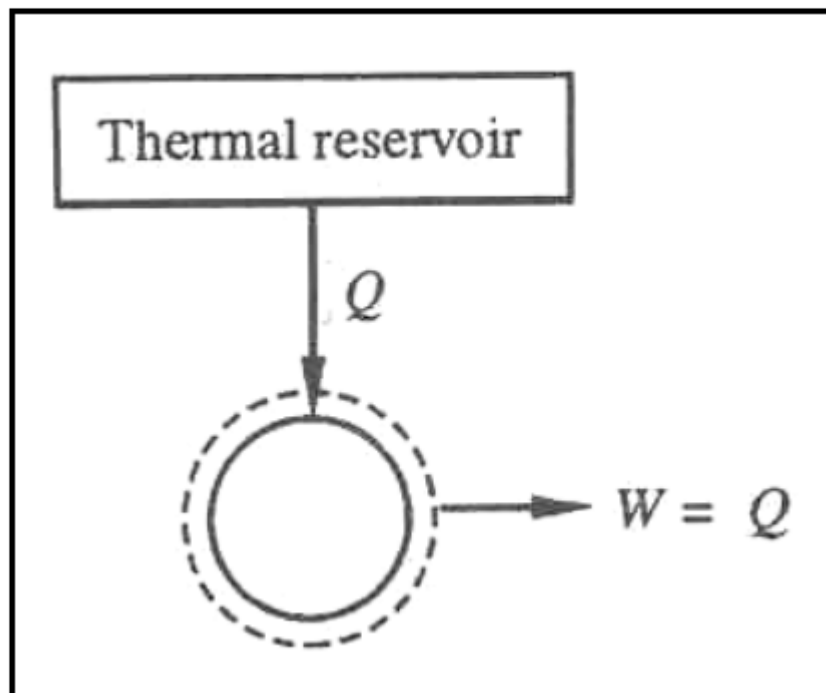

For a 1-T engine the thermal efficiency $\eta = W/Q = 1$. No heat engine can have efficiency equal to unity.

Clausius statement

It is not possible for heat to flow from a colder body to a warmer body without any work having been done to accomplish this flow. Energy will not flow spontaneously from a low temperature object to a higher temperature object. This precludes a perfect refrigerator. The statements about refrigerators apply to air conditioners and heat pumps, which embody the same principles.

This is the "second form" or Clausius statement of the second law.

OR

It is impossible to construct a device that operates in a cycle and produces no effect other than the transfer of heat from a lower-temperature body to higher-temperature body.

Equivalence of Kelvin-Planck and Clausius Statements

To prove that violation of the Kelvin-Planck Statement leads to a violation of the Clausius Statement, let us assume that Kelvin-Planck statement is incorrect.

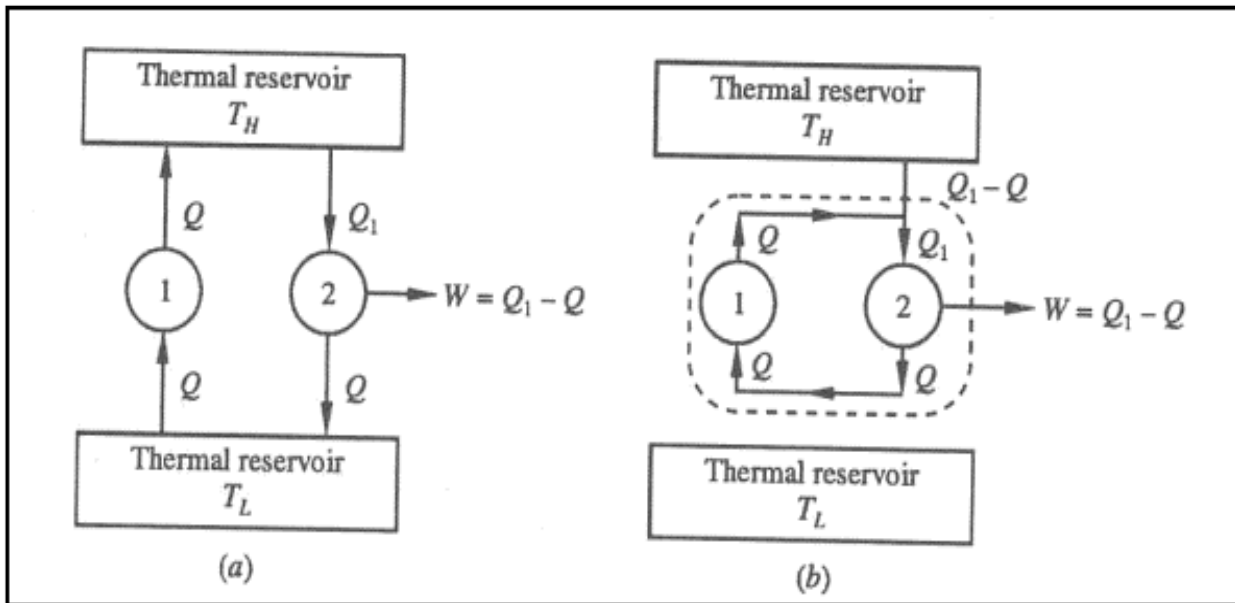

Consider a cyclically working device 1, which absorbs energy Q_1 as heat from a thermal reservoir at T_H . Equivalent amount of work $W(W=Q_1)$ is performed.

Consider another device 2 operating as a cycle, which absorbs energy Q_L as heat from a low temperature thermal reservoir at T_L and rejects energy Q_H ($Q_H=Q_L+W$). Such a device does not violate Clausius statement.

If the two devices are now combined, the combined device (enclosed by the dotted boundary) transfers heat Q_L from the low temperature reservoir at T_L to a high temperature reservoir at T_H without receiving any aid from an external agent, which is the violation of the Clausius statement.

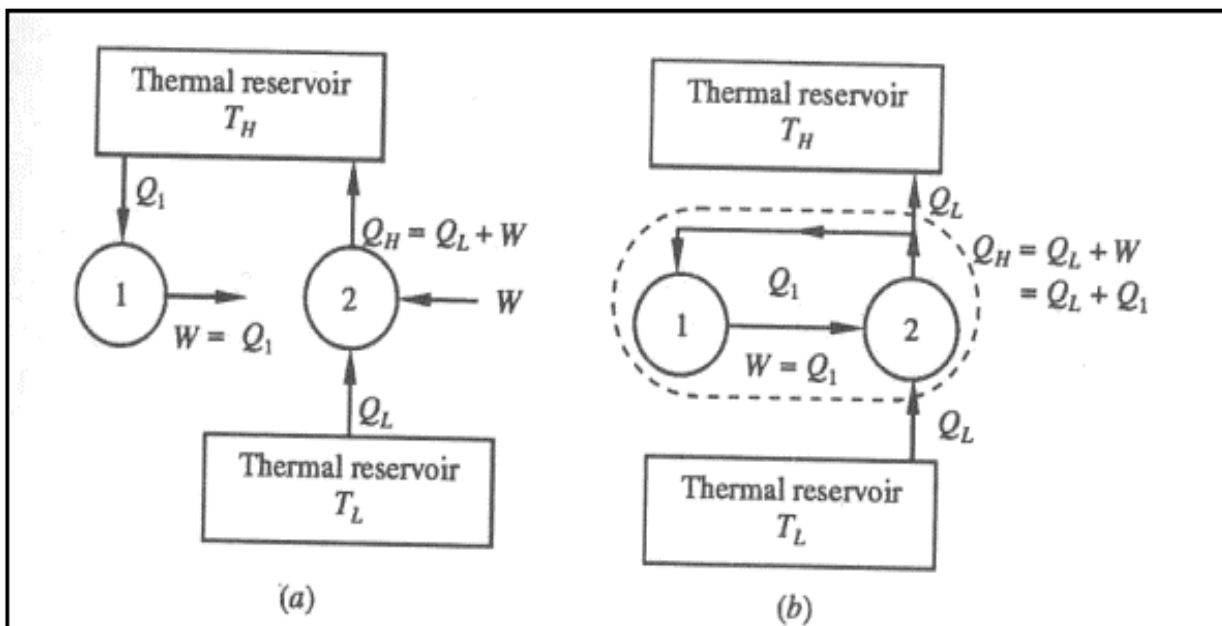

Likewise let us assume that the Clausius statement is incorrect. So we have a device 1, cyclically working transferring heat Q from a low temperature reservoir at T_L to a high temperature thermal reservoir at T_H . Consider another device 2, which absorbs heat Q_1 from a high temperature reservoir at T_H does work W and rejects energy Q as heat tot the low temperature reservoir at T_L as shown in

figure.

If the two devices are combined (shown in figure by a dotted enclosure), then the combined device receives energy ($Q_1 - Q$) as heat from a thermal reservoir and delivers equivalent work ($W = Q_1 - Q$) in violation of the Kelvin-Planck statement.

Therefore violation of Clausius statement leads to the violation of the Kelvin-Planck statement. Hence, these two statements are equivalent.

Corollaries of the Second Law

There are many propositions that are derived from the second law. The corollaries of the second law are listed below:

Corollary 1—The Clausius statement of the second law.

Corollary 2, 3, 4—“Carnot Principles.”

Corollary 5—Establishes an absolute temperature scale independent of the thermometric substance.

Corollary 6—The Clausius inequality.

Corollary 7—Gives the definition of “entropy”.

Corollary 8—Discussion of the entropy of an isolated system.

Corollary 1—The Clausius Statement

Corollary 2—Efficiency of the Reversible Engines

There is no heat engine operating between a source and a sink that can have a greater efficiency than a reversible heat engine operating between the same two thermal reservoirs.

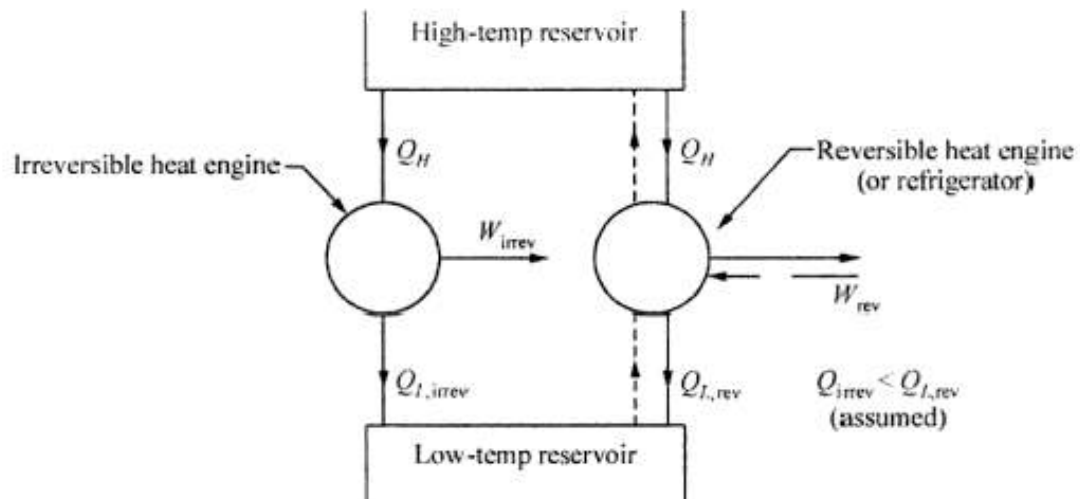

Fig. 3.8 Reversible and irreversible engines.

Let us assume that the thermal efficiency of the irreversible engine, $\eta_{th,irrev}$, in Fig. 3.8 is greater than that of the reversible engine, $\eta_{th,rev}$. This assumption contradicts the first principle of Carnot, Corollary 2 of the second law. Hence,

Let us assume that the thermal efficiency of the irreversible engine, $\eta_{th,irrev}$, in Fig. 3.8 is greater than that of the reversible engine, $\eta_{th,rev}$. This assumption contradicts the first principle of Carnot, Corollary 2 of the second law. Hence,

$$\eta_{th,irrev} > \eta_{th,rev}$$

So, from Eq. (3.1) we can write

$$\left(\frac{Q_H - Q_L}{Q_H} \right)_{irrev} > \left(\frac{Q_H - Q_L}{Q_H} \right)_{rev}$$

But,

$$Q_H - Q_L = W_{net}$$

\therefore

$$\left(\frac{W_{net}}{Q_H} \right)_{irrev} > \left(\frac{W_{net}}{Q_H} \right)_{rev}$$

Since,

$$Q_{H,irrev} = Q_{H,rev}$$

$$\therefore (W_{\text{net}})_{\text{irrev}} > (W_{\text{net}})_{\text{rev}}$$

Now, consider that the reversible heat engine is reversed to operate as a refrigerator, which receives an input work W_{rev} and rejects heat to the high-temperature reservoir. As the refrigerator rejects heat Q_H to the high-temperature reservoir and the irreversible heat engine receives the same amount of heat from the same reservoir the net heat transfer from the reservoir is zero. Hence, instead of providing the reservoir the rejected heat Q_H from the refrigerator can be put directly to the irreversible heat engine. The resulting refrigerator–irreversible heat engine combination is depicted in Fig. 3.9. The combination will produce a net work equal to $(W_{\text{irrev}} - W_{\text{rev}})$ and exchange heat with a single reservoir.

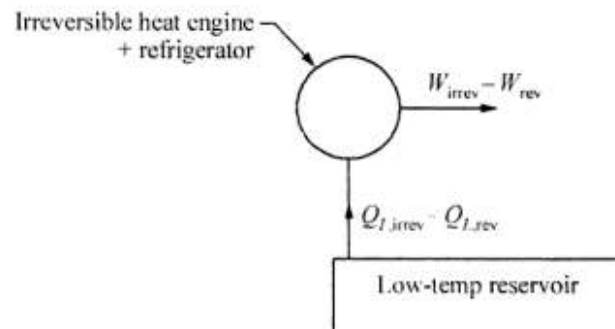

Fig. 3.9 Combination of refrigerator and irreversible heat engine.

This is a clear violation of the Kelvin–Planck statement and gives rise to the perpetual motion machine of the second kind. Hence, our assumption that the efficiency of the irreversible engine is greater than the efficiency of the reversible engine is incorrect and the corollary is a valid statement.

Corollary 3—Equality of Reversible Engines

According to the corollary, all reversible engines operating between the same temperature limits will have equal efficiency. As in this case, efficiency of one reversible engine cannot be greater than that of the other, the corollary is viable.

Corollary 4—Efficiency of Reversible Engines and Characteristics of the Working Media

The efficiency of a reversible engine operating between two temperature limits is independent of the characteristics of the working medium and depends only on the temperature limits. Let a Carnot engine and a reversible engine operate between the same two reservoirs. Efficiency of a Carnot engine, from Eq. (3.5), is given by

$$\eta_{\text{Carnot}} = 1 - \frac{Q_L}{Q_H}$$

According to Corollary 3,

$$\eta_{\text{rev}} = \eta_{\text{Carnot}} = 1 - \frac{Q_L}{Q_H} = \phi(T_L, T_H) \quad (3.6)$$

Corollary 7—Entropy

The Clausius inequality leads to a property of a system called *entropy* (see Fig. 3.11). The system undergoes a reversible process from state point 1 to 2, along path *A*, and let it complete the cycle following path *B*.

For a reversible cycle

$$\oint \frac{\delta Q}{T} = 0$$

$$\Rightarrow \int_{1A}^{2A} \frac{\delta Q}{T} + \int_{2B}^{1B} \frac{\delta Q}{T} = 0 \quad (3.17)$$

Now, let the system follows another reversible cycle 1A2C1. For this reversible cycle

$$\int_{1A}^{2A} \frac{\delta Q}{T} + \int_{2C}^{1C} \frac{\delta Q}{T} = 0 \quad (3.18)$$

Hence, the integrated term is remaining the same for all the reversible paths between 1 and 2. It is a function of the end states only, and is path independent. So we can call it a property. This property is called entropy and is designated S , with

$$dS = \left(\frac{\delta Q}{T} \right)_{\text{rev}} \quad (3.19)$$

Entropy is an extensive property of a system and it is also known as total entropy. Entropy per unit mass, s , is an intensive property.

Integration of Eq. (3.19) will give the change in S during a process.

$$\Delta S = S_2 - S_1 = \int_1^2 \left(\frac{\delta Q}{T} \right)_{\text{rev}} \quad (3.20)$$

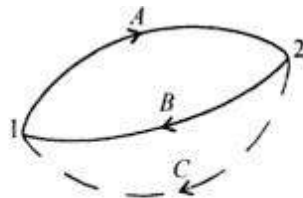

Fig. 3.12 One reversible and one irreversible cycle.

Now consider Fig. 3.12. Here the cycle 1A2B1 is reversible, but the path 2C1 being irreversible the cycle 1A2C1 is irreversible.

For the reversible cycle 1A2B1

$$\oint \frac{\delta Q}{T} = \int_{1A}^{2A} \frac{\delta Q}{T} + \int_{2B}^{1B} \frac{\delta Q}{T} = 0 \quad (3.21)$$

For the irreversible cycle 1A2C1, from the inequality of Clausius

$$\oint \frac{\delta Q}{T} = \int_{1A}^{2A} \frac{\delta Q}{T} + \int_{2C}^{1C} \frac{\delta Q}{T} < 0 \quad (3.22)$$

Subtracting Eq. (3.22) from Eq. (3.21) we get

$$\int_{2B}^{1B} \frac{\delta Q}{T} > \int_{2C}^{1C} \frac{\delta Q}{T}$$

But, path B is reversible and entropy is path independent.

$$\therefore \int_{2B}^{1B} \frac{\delta Q}{T} = \int_{2B}^{1B} dS = \int_{2C}^{1C} dS$$

Hence

$$\int_{2C}^{1C} dS > \int_{2C}^{1C} \frac{\delta Q}{T}$$

In general, the above equation can be modified as

$$dS \geq \frac{\delta Q}{T}$$

or

$$S_2 - S_1 \geq \int_1^2 \frac{\delta Q}{T} \quad (3.23)$$

For a reversible process,

$$dS = \frac{\delta Q}{T}$$

And for an irreversible process,

$$dS > \frac{\delta Q}{T}$$

So, entropy is an index of unavailability or degradation of energy. Heat flows, by nature, from hot to cold bodies, thus becoming degraded or less available. Energy going to sink becomes less available for work though most of it may be recovered by heat economy devices. This amount of unavailability is given by entropy. Generally we are concerned with change of entropy.

The Principle of Increase of Entropy

Equation (3.23) is very important in the realm of thermodynamics.

Let us consider the entropy change of the universe when a system performs a reversible process. During any infinitesimal portion of this reversible process, let an amount of heat δQ is transferred from a reservoir to the system at a temperature T .

$$dS_{\text{system}} = +\frac{\delta Q}{T}$$

$$dS_{\text{reservoir}} = -\frac{\delta Q}{T}$$

Hence,
$$dS_{\text{universe}} = dS_{\text{system}} + dS_{\text{reservoir}} = 0 \quad (3.24)$$

So, in the case of a reversible heat transfer, the change of entropy of the universe is zero. Obviously, if dQ is zero, the entropies of both the system and the surroundings remain unchanged. As the above remark holds good for any infinitesimal portion of the process, it should be true for the entire process as well.

Let us now consider an irreversible process. Consider a heat transfer δQ from a source at T_H to a sink at T_L . The source loses an amount of entropy $\delta Q/T_H$ and sink gains $\delta Q/T_L$. But, T_H being greater than T_L there is a net gain in entropy, like

$$dS_{\text{universe}} = dS_{\text{system}} + dS_{\text{surroundings}}$$

$$= -\frac{\delta Q}{T_H} + \frac{\delta Q}{T_L}$$

$$= \delta Q \left(\frac{1}{T_L} - \frac{1}{T_H} \right) > 0$$

Hence, an irreversible heat transfer leads to an increase in entropy. According to Lord Kelvin, the entropy increases continuously when spontaneous processes occur in nature. Clausius stated that the energy of the Universe remains constant and the entropy of the same increases towards the maximum.

Thus, the principle of increase of entropy can be stated as:

Of all states at which the stored energy (for a simple system, stored energy can be replaced by internal energy) of the system is the same, the most stable state is the one that corresponds to the maximum entropy.

Corollary 8—Entropy of an Isolated System

Often the principle of the increase of entropy is stated in terms of an isolated system, a system in which there is no interaction between the system and its surroundings. In this case,

$$dS_{\text{isolated system}} \geq 0 \quad (3.26)$$

Since the system and its surroundings are two sub-systems of the isolated system,

$$dS_{\text{isolated system}} = dS_{\text{system}} + dS_{\text{surroundings}} = dS_{\text{gen}} \quad (3.27)$$

where dS_{gen} is called the *entropy generation* due to irreversibility. Since all real processes are irreversible, entropy generation is always positive. Practically, it is a non-zero quantity and process dependent. It is not a property of the system. For a reversible process it is zero. There should be effort to design a process that has the minimum entropy generation.

The Increase of Entropy for Closed Systems

The increase in entropy for a closed system is the difference between the initial and final entropies of the system, as there is no mass flow across the boundary.

In this case

$$dS_{\text{gen}} = dS_{\text{system}} + dS_{\text{surroundings}} \geq 0 \quad \text{or} \quad S_{\text{gen}} = \Delta S_{\text{system}} + \Delta S_{\text{surroundings}} \geq 0 \quad (3.28)$$

where

$$\Delta S_{\text{system}} = (S_2 - S_1)_{\text{system}} = m(s_2 - s_1)$$

And

$$\Delta S_{\text{surroundings}} = \frac{Q_{\text{surroundings}}}{T_{\text{surroundings}}}$$

The Increase of Entropy for Control Volumes

This is similar to a closed system, but there is mass flow across the boundary of the control volume.

The change in entropy of the control volume

$$\Delta S_{\text{cv}} = (S_2 - S_1)_{\text{cv}}$$

And

$$\Delta S_{\text{surroundings}} = \frac{Q_{\text{surroundings}}}{T_{\text{surroundings}}} + S_e - S_i$$

where the subscripts 1 and 2 indicate the initial and final states, respectively, in the control volume and the subscripts i and e denote the inlet and exit states of the control volume respectively. S_i is the total entropy transported into the control volume from the surroundings and S_e is the total entropy transported out of the control volume into the surroundings, with the mass leaving the control volume.

Perpetual motion machine of the second kind

The first law of thermodynamics does not stipulate any restriction on the thermal efficiency of a heat engine. However, the second law restricts the thermal efficiency of a heat engine to less than one. It stipulates that some portion of the energy absorbed as heat from a source must always be rejected to a low temperature sink. Wilhelm Ostwald introduced the concept of Perpetual Motion Machine of the Second Kind, that is, of a device which could perform work solely by absorbing energy as heat from a single thermal reservoir (see Fig. 7.4). Clearly, such a device does not violate the first law of thermodynamics because it would perform work at the expense of the internal energy of a body. A Perpetual Motion Machine of the Second Kind (PMMSK) is a hypothetical device which, working cyclically, receives energy as heat from a single thermal reservoir and delivers an equivalent amount of work.

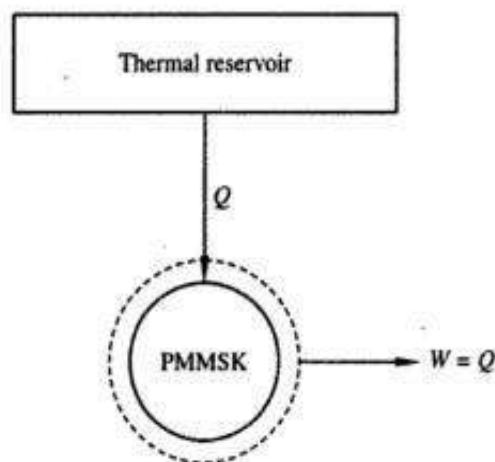
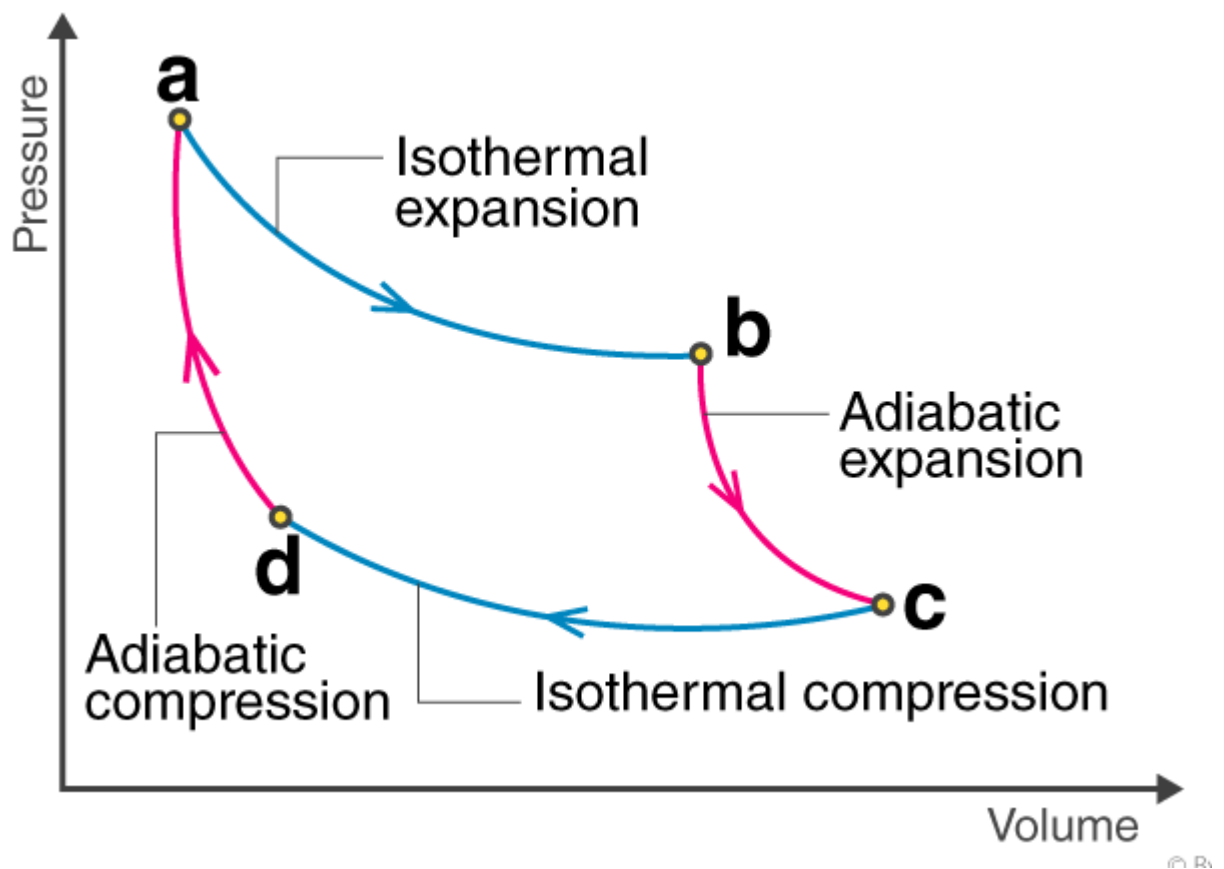

Fig. 7.4 *Perpetual motion machine of the second kind*

THE CARNOT CYCLE

We mentioned earlier that heat engines are cyclic devices and that the working fluid of a heat engine returns to its initial state at the end of each cycle. Work is done by the working fluid during one part of the cycle and on the working fluid during another part. The difference between these two is the net work delivered by the heat engine. The efficiency of a heat-engine cycle greatly depends on how the individual processes that make up the cycle are executed. The net work, thus the cycle efficiency, can be maximized by using processes that require the least amount of work and deliver the most,



that is, by using *reversible processes*. Therefore, it is no surprise that the most efficient cycles are reversible cycles, that is, cycles that consist entirely of reversible processes.

Reversible cycles cannot be achieved in practice because the irreversibilities associated with each process cannot be eliminated. However, reversible cycles provide upper limits on the performance of real cycles. Heat engines and refrigerators that work on reversible cycles serve as models to which actual heat engines and refrigerators can be compared. Reversible cycles also serve as starting points in the development of actual cycles and are modified as needed to meet certain requirements.

Probably the best known reversible cycle is the **Carnot cycle**, first proposed in 1824 by French engineer Sadi Carnot. The theoretical heat engine that operates on the Carnot cycle is called the **Carnot heat engine**. The Carnot cycle is composed of four reversible processes—two isothermal and two adiabatic—and it can be executed either in a closed or a steady-flow system.

Consider a closed system that consists of a gas contained in an adiabatic piston–cylinder device, as shown in Fig. 6–37. The insulation of the cylinder head is such that it may be removed to bring the cylinder into contact with reservoirs to provide heat transfer. The four reversible processes that make up the Carnot cycle are as follows:

Reversible Isothermal Expansion (process 1-2, $T_H = \text{constant}$). Initially (state 1), the temperature of the gas is T_H and the cylinder head is in close contact with a source at temperature T_H . The gas is allowed to expand slowly, doing work on the surroundings. As the gas expands, the temperature of the gas tends to decrease. But as soon as the temperature drops by an infinitesimal amount dT , some heat is transferred from the reservoir into the gas, raising the gas temperature to T_H . Thus, the gas temperature is kept constant at T_H . Since the temperature difference between the gas and the reservoir never exceeds a differential amount dT , this is a reversible heat transfer process. It continues until the piston reaches position 2. The amount of total heat transferred to the gas during this process is Q_H .

Reversible Adiabatic Expansion (process 2-3, temperature drops from T_H to T_L). At state 2, the reservoir that was in contact with the cylinder head is removed and replaced by insulation so that the system becomes adiabatic. The gas continues to expand slowly, doing work on the surroundings until its temperature drops from T_H to T_L (state 3). The piston is assumed to be frictionless and the process to be quasi-equilibrium, so the process is reversible as well as adiabatic.

Reversible Isothermal Compression (process 3-4, $T_L = \text{constant}$). At state 3, the insulation at the cylinder head is removed, and the cylinder is brought into contact with a sink at temperature T_L . Now the piston is pushed inward by an external force, doing work on the gas. As the gas is compressed, its temperature tends to rise. But as soon as it rises by an infinitesimal amount dT , heat is transferred from the gas to the sink, causing the gas temperature to drop to T_L . Thus, the gas temperature remains constant at T_L . Since the temperature difference between the gas and the sink never exceeds a differential amount dT , this is a reversible

heat transfer process. It continues until the piston reaches state 4. The amount of heat rejected from the gas during this process is Q_L .

Reversible Adiabatic Compression (process 4-1, temperature rises from T_L to T_H). State 4 is such that when the low-temperature reservoir is removed, the insulation is put back on the cylinder head, and the gas is compressed in a reversible manner, the gas returns to its initial state (state 1). The temperature rises from T_L to T_H during this reversible adiabatic compression process, which completes the cycle.

The P - V diagram of this cycle is shown in Fig. 6-38. Remembering that on a P - V diagram the area under the process curve represents the boundary work for quasi-equilibrium (internally reversible) processes, we see that the area under curve 1-2-3 is the work done by the gas during the expansion part of the cycle, and the area under curve 3-4-1 is the work done on the gas during the compression part of the cycle. The area enclosed by the path of the cycle (area 1-2-3-4-1) is the difference between these two and represents the net work done during the cycle.

Notice that if we acted stingily and compressed the gas at state 3 adiabatically instead of isothermally in an effort to save Q_L , we would end up back at state 2, retracing the process path 3-2. By doing so we would save Q_L , but we would not be able to obtain any net work output from this engine. This illustrates once more the necessity of a heat engine exchanging heat with at least two reservoirs at different temperatures to operate in a cycle and produce a net amount of work.

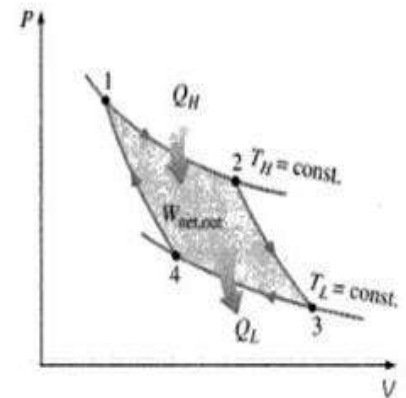

FIGURE 6-38
 P - V diagram of the Carnot cycle.

The Carnot cycle can also be executed in a steady-flow system. It is discussed in later chapters in conjunction with other power cycles.

Being a reversible cycle, the Carnot cycle is the most efficient cycle operating between two specified temperature limits. Even though the Carnot cycle cannot be achieved in reality, the efficiency of actual cycles can be improved by attempting to approximate the Carnot cycle more closely.

The thermal efficiencies of actual and reversible heat engines operating between the same temperature limits compare as follows (Fig. 6-47):

$$\eta_{th} \begin{cases} < \eta_{th,rev} & \text{irreversible heat engine} \\ = \eta_{th,rev} & \text{reversible heat engine} \\ > \eta_{th,rev} & \text{impossible heat engine} \end{cases} \quad (6-19)$$

Clausius inequality

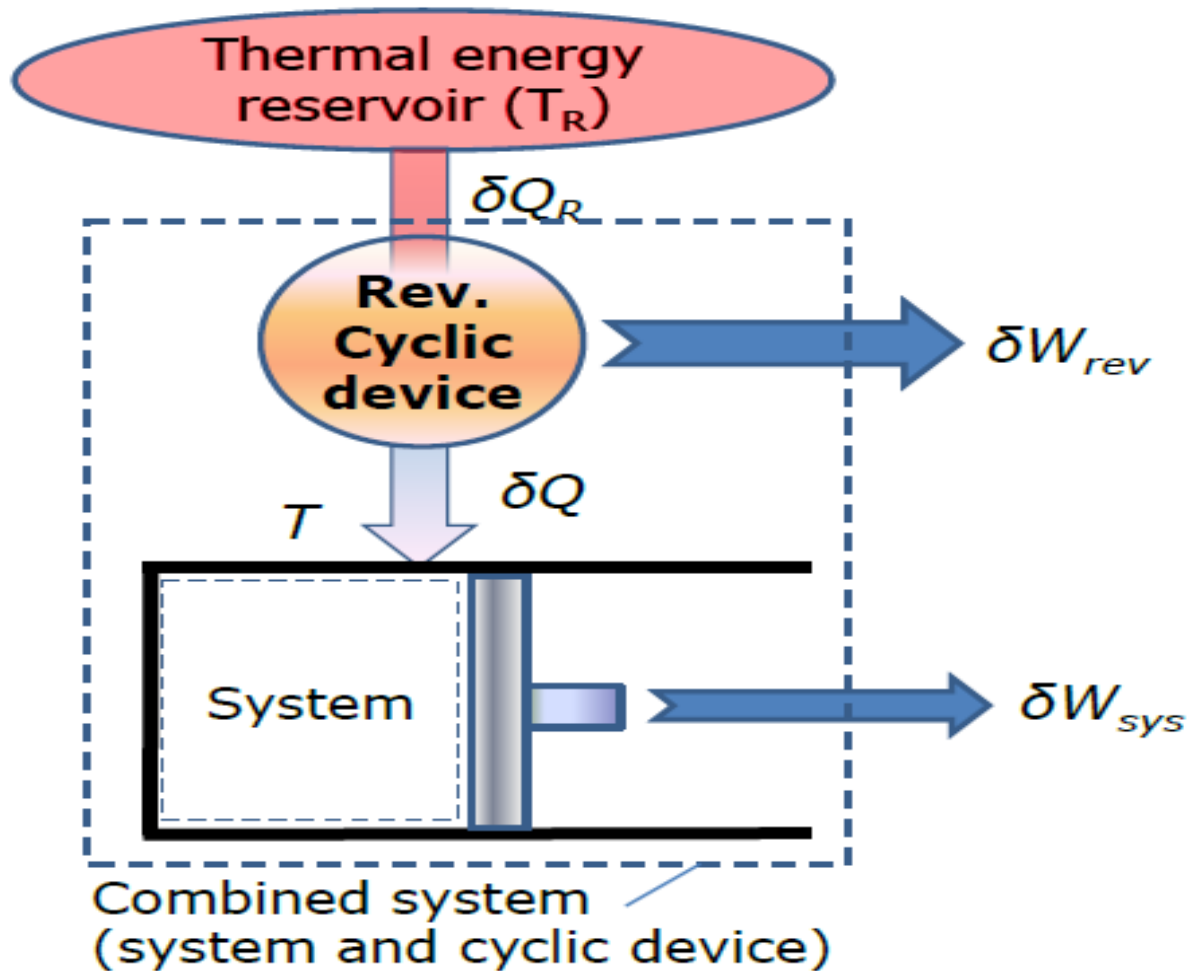

Clausius inequality

- Applying the energy balance to the combined system identified by dashed lines yields: $\delta W_C = \delta Q_R - dE_C$
- where δW_C is the total work of the combined system ($\delta W_{rev} + \delta W_{sys}$) and dE_C is the change in the total energy of the combined system.
- Considering that the cyclic device is a reversible one $\frac{\delta Q_R}{T_R} = \frac{\delta Q}{T}$

- From the above equations:

$$\delta W_C = T_R \frac{\delta Q}{T} - dE_C$$

- Let the system undergo a cycle while the cyclic device undergoes an integral number of cycles

$$W_C = T_R \oint \frac{\delta Q}{T}$$

- Since the cyclic integral of energy is zero.

- The combined system is exchanging heat with a single thermal energy reservoir while involving (producing or consuming) work W_C during a cycle. Hence W_C cannot be a work output, and thus it cannot be a positive quantity.
- Considering T_R to be a positive quantity,

$$\oint \frac{\delta Q}{T} \leq 0$$

- This is the **Clausius inequality**.
- Clausius inequality is valid for all thermodynamic cycles, reversible or irreversible, including the refrigeration cycles.
- If no irreversibilities occur within the system as well as the reversible cyclic device, then the cycle undergone by the combined system is internally reversible.

$$\oint \left(\frac{\delta Q}{T} \right)_{\text{int. rev}} = 0$$

Clausius inequality provides the criterion for the irreversibility of a process.

$\oint \frac{\delta Q}{T} = 0$, the process is reversible.

$\oint \frac{\delta Q}{T} < 0$, the process is irreversible and possible.

$\oint \frac{\delta Q}{T} > 0$, the process is impossible.

- The cyclic integral of work and heat are not zero.
- However, the cyclic integral of volume (or any other property) is zero.
- Conversely, a quantity whose cyclic integral is zero depends on the state only and not the process path, and thus it is a property
- Clausius realized in 1865 that he had discovered a new thermodynamic property, and he chose to name this property **entropy**.

The property of entropy

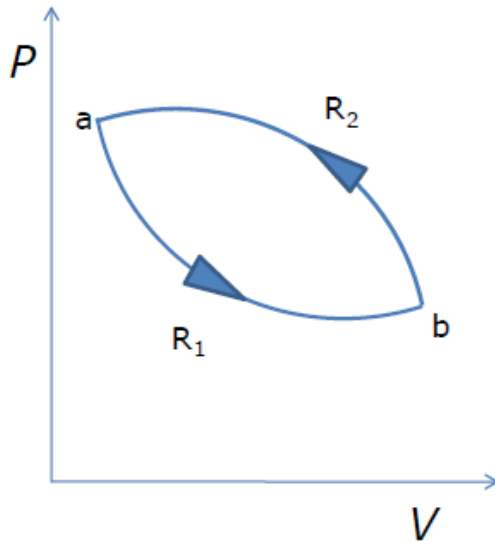

$$\oint_{R_1 R_2} \frac{dQ}{T} = 0$$

$$R_1 \int_a^b \frac{dQ}{T} + \int_{R_2}^a \frac{dQ}{T} = 0$$

$$\text{OR, } \int_{R_1}^b \frac{dQ}{T} = - \int_{R_2}^a \frac{dQ}{T}$$

Since R_2 is a reversible path,

$$R_1 \int_a^b \frac{dQ}{T} = \int_{R_2}^b \frac{dQ}{T}$$

- $\int_a^b \frac{dQ}{T}$ is independent of the reversible path connecting a and b .
- This property whose value at the final state minus the initial state is equal to $\int_a^b \frac{dQ}{T}$ is called **entropy**, denoted by S .

$$\int_a^b \frac{dQ}{T} = S_b - S_a$$

- When the two equilibrium states are infinitesimally near,

$$\frac{dQ_R}{T} = dS$$

Entropy

- Entropy is an extensive property of a system and sometimes is referred to as **total entropy**. Entropy per unit mass, designated s , is an intensive property and has the unit $\text{kJ/kg} \cdot \text{K}$
- The entropy change of a system during a process can be determined by

$$\Delta S = S_2 - S_1 = \int_1^2 \left(\frac{\delta Q}{T} \right)_{\text{int. rev.}} \quad (\text{kJ/kg})$$

- Entropy is a property, and like all other properties, it has fixed values at fixed states.
- Therefore, the entropy change dS between two specified states is the same no matter what path, reversible or irreversible.

Principle of increase of entropy

Let a system change from state 1 to state 2 by a reversible process A and return to state 1 by another reversible process B. Then 1A2B1 is a reversible cycle. Therefore, the Clausius inequality gives:

$$\int_{1A2B1} dQ/T = \int_{1A2} dQ/T + \int_{2B1} dQ/t = 0$$

If the system is restored to the initial state from 1 to state 2 by an irreversible process C, then 1A2C1 is an irreversible cycle. Then the Clausius inequality gives:

$$\int_{1A2C1} dQ/T = \int_{1A2} dQ/T + \int_{2C1} dQ/t = 0$$

Subtracting the above equation from the first one,

$$\int_{2B1} dQ/T > \int_{2C1} dQ/T$$

Since the process 2B1 is reversible,

$$\int_{2B1} dQ/T = \int_1^2 dQ/T \quad \text{or,} \quad \int_1^2 dS > \int_{2C1} dQ/T$$

In general,

$$dS \geq dQ/T$$

Where the equality sign holds good for a reversible process and the inequality sign holds good for an irreversible process.

Now let us apply the above result to evaluate the entropy change of the universe when a system interacts with its surroundings and exchanges energy as heat with the surroundings.

Let T_{sur} and T_{sys} be the temperatures of the surroundings and the system such that $T_{sur} > T_{sys}$.

Let dQ represent the energy transfer as heat from the surroundings to the system during the given irreversible process.

$$dS_{sys} = dQ/T_{sys}$$

$$dS_{sur} = -dQ/T_{sur}$$

$$dS_{uni} = dS_{sys} + dS_{sur} = (dQ/T)_{sys}$$

$$(dQ/T)_{sur} > 0$$

$$dS_{uni} > 0 \text{ (since } T_{sur} > T_{sys} \text{)}$$

If the system is isolated, there is no change in the entropy of the surroundings and $dS = 0$, for an isolated system

Therefore the entropy of an isolated system either increases or, in the limit, remains constant.

The equality sign holds good when the process undergone by the system is reversible, the inequality sign holds good if there is any irreversibility present in the process. This statement is usually called the **principle of entropy increase**.

Irreversible or spontaneous processes can occur only in that direction for which the entropy of the universe or that of an isolated system, increases. These processes cannot occur in the direction of decreasing entropy.

For an isolated system,

$DS > 0$, for irreversible processes

$DS = 0$, for reversible processes

$DS < 0$, the process is impossible

Thermodynamic potentials

Thermodynamic potentials are state functions that, together with the corresponding equations of state, describe the equilibrium behavior of a system as a function of so-called "natural variables". The natural variables are a set of appropriate variables that allow to compute other state functions by partial differentiation of the thermodynamic potentials.

Thermodynamic Relations

Consider a simple compressible substance without any motion or gravitational effects. Then the first law for a change of state can be obtained as

$$\delta Q = dU + \delta W$$

For a reversible process of a simple compressible substance we get

$$\delta Q = T dS \text{ and } \delta W = p dV$$

Substituting these relations into the first-law equation we have

$$T dS = dU + p dV \quad (3.85)$$

This is one of the two important relations.

Again, enthalpy is defined as

$$H = U + pV$$

Differentiating we get

$$dH = dU + p dV + V dp$$

Using Eq. (3.85) we can write

$$dH = T dS + V dp$$

or

$$T dS = dH - V dp \quad (3.86)$$

This is the second important relation.

On unit mass basis

$$T ds = du + p dv \quad (3.87a)$$

And

$$T ds = dh - v dp \quad (3.87b)$$

On mole basis

$$T d\bar{s} = d\bar{u} + p d\bar{v} \quad (3.88a)$$

And

$$T d\bar{s} = d\bar{h} - \bar{v} dp \quad (3.88b)$$

By devising a different reversible path, connecting the final state with the initial state, the entropy change for an ideal gas can be estimated by the following equation also.

$$\Delta s = C_p \ln \left(\frac{v_2}{v_1} \right) + C_v \ln \left(\frac{P_2}{P_1} \right) \quad (8.1)$$

When an ideal gas undergoes a change of state from P_1, v_1, T_1 to P_2, v_2, T_2 , the entropy change of the gas can be estimated by any of the above three equations. Depending on the independent variables, we choose the appropriate equation for estimating Δs . However, these relations can be used only for an ideal gas and not for any other substance.

The above equations express the entropy in terms of two independent variables which can be easily measured. Since entropy plays an important role in thermodynamic analysis of processes, a knowledge of the estimation of entropy change of a substance is essential. A differential change in the entropy associated with the differential change in the independent variables can be expressed as:

$$s = s(T, P)$$

$$ds = \left(\frac{\partial s}{\partial T} \right)_P dT + \left(\frac{\partial s}{\partial P} \right)_T dP \quad (8.2)$$

$$s = s(T, v)$$

$$ds = \left(\frac{\partial s}{\partial T} \right)_v dT + \left(\frac{\partial s}{\partial v} \right)_T dv \quad (8.3)$$

$$s = s(P, v)$$

$$ds = \left(\frac{\partial s}{\partial P} \right)_v dP + \left(\frac{\partial s}{\partial v} \right)_P dv \quad (8.4)$$

These relations can be integrated to obtain Δs . To integrate these relations, a knowledge of the six partial derivatives of entropy, namely, $(\partial s/\partial T)_P$; $(\partial s/\partial T)_v$; $(\partial s/\partial P)_T$; $(\partial s/\partial P)_v$; $(\partial s/\partial v)_T$ and $(\partial s/\partial v)_P$, is essential. Of these, the partial derivatives of entropy with respect to temperature are related to the specific heats C_p and C_v by the equations:

$$C_p = T \left(\frac{\partial s}{\partial T} \right)_P \quad (8.5)$$

$$C_v = T \left(\frac{\partial s}{\partial T} \right)_v \quad (8.6)$$

The remaining four partial derivatives of entropy are expressed in terms of the measurable quantities by equations known as the Maxwell relations and are discussed below.

Combining the first and second laws of thermodynamics, we get

$$du = Tds - Pd v$$

Since u is a property, its differential must be exact. Applying the criterion for exactness, we get

$$\left(\frac{\partial T}{\partial v} \right)_s = - \left(\frac{\partial P}{\partial s} \right)_v \quad (8.7)$$

The term $(\partial T/\partial v)_s$ represents the slope of an isentropic curve on a $T-v$ diagram and this slope can be easily measured or estimated. This is related to the partial derivative of entropy with respect to pressure at constant volume. Therefore, Eq. (8.7) is a Maxwell relation.

Since $h = u + Pv$, or $H = U + PV$, we get

$$dh = du + Pdv + vdP \quad \text{or} \quad dH = dU + Pdv + VdP \quad (8.8)$$

Substituting Eq. (7.104) in Eq. (8.8), we get

$$dh = Tds + vdP \quad \text{or} \quad dH = TdS + VdP \quad (8.9)$$

We shall define two other thermodynamic properties of matter. The Helmholtz function a or A is defined as

$$a = u - Ts \quad \text{or} \quad A = U - TS \quad (8.10)$$

Then

$$dA = dU - Tds - SdT \quad \text{or} \quad da = du - Tds - sdT \quad (8.11)$$

Substituting Eq. (7.104) in Eq. (8.11), we get

$$dA = -PdV - SdT \quad \text{or} \quad da = -Pdv - sdT \quad (8.12)$$

The Gibbs free energy G or g is defined as

$$G = H - TS \quad \text{or} \quad g = h - Ts \quad (8.13)$$

Then

$$dG = dH - Tds - SdT \quad \text{or} \quad dg = dh - Tds - sdT \quad (8.14)$$

Substituting for dH from Eq. (8.9) in Eq. (8.14), we get

$$dG = -SdT + VdP \quad \text{or} \quad dg = -sdT + vdP \quad (8.15)$$

Note that the independent variables of U, H, A and G include P, v, T and s only. The equations (8.9), (8.12) and (8.15) are sometimes referred to as the *Gibbsian Equations*. Applying the criterion for exactness to Eqs. (8.9), (8.12) and (8.15), we get

$$\left(\frac{\partial T}{\partial P}\right)_s = \left(\frac{\partial v}{\partial s}\right)_P \quad (8.16)$$

$$\left(\frac{\partial P}{\partial T}\right)_v = \left(\frac{\partial s}{\partial v}\right)_T \quad (8.17)$$

$$\left(\frac{\partial s}{\partial P}\right)_T = -\left(\frac{\partial v}{\partial T}\right)_P \quad (8.18)$$

The Eqs. (8.7) and (8.16)–(8.18) are the well known Maxwell relations.

Third law of thermodynamics -

A very important consideration in thermodynamics concerns the meaning of the zero on the absolute scale of temperature, i.e 0 K. Though the full significance of this issue can only be unravelled through considerations of *Quantum Statistical Mechanics*, thermodynamics comes with very strong pointers that 0 K is indeed a very special temperature.

A practical question that first comes to mind is whether this temperature is physically realizable, and if so, how? A somewhat related question is whether its existence is in conformity with the first and second laws of thermodynamics. Let us begin by recounting an objection to absolute zero that would be the first reaction by many. This is based on the premise that a Carnot cycle operating between 0 K and any other T , would be a *perfect heat engine* in the sense that its efficiency $\eta = 1 - \frac{0}{T} = 1!$ This would most directly contradict the Kelvin postulate and hence the second law.

Therefore, if the isothermal variation of entropy *vanishes* at absolute zero, one can not have two distinct adiabats intersecting the $T = 0$ isotherm, and no Carnot cycle can be operated, removing that particular objection to absolute zero. But evading inconsistency with second law by taking refuge under the assumption of a vanishing $\left(\frac{\partial S}{\partial \xi}\right)_{T=0}$, lands one in a different kind of difficulty. That difficulty is that when $\left(\frac{\partial S}{\partial \xi}\right)_{T=0} = 0$, *absolute zero is simply unattainable!* So there are two *logically distinct* aspects to the absolute zero issue; one being some system already existing in it, and the other being the attainability of absolute zero from an initial $T \neq 0K$.

Q6.1 An inventor claims to have developed an engine that takes in 105 MJ at a temperature of 400 K, rejects 42 MJ at a temperature of 200 K, and delivers 15 kWh of mechanical work. Would you advise investing money to put this engine in the market?

(Ans. No)

Solution: Maximum thermal efficiency of his engine possible

$$\eta_{\max} = 1 - \frac{200}{400} = 50\%$$

\therefore That engine and deliver output = $\eta \times$ input

$$= 0.5 \times 105 \text{ MJ}$$

$$= 52.5 \text{ MJ} = 14.58 \text{ kWh}$$

As he claims that his engine can deliver more work than ideally possible so I would not advise to investing money.

Q6.2 If a refrigerator is used for heating purposes in winter so that the atmosphere becomes the cold body and the room to be heated becomes the hot body, how much heat would be available for heating for each kW input to the driving motor? The COP of the refrigerator is 5, and the electromechanical efficiency of the motor is 90%. How does this compare with resistance heating?

(Ans. 5.4 kW)

Solution:
$$\text{COP} = \frac{\text{desired effect}}{\text{input}}$$

$$(\text{COP})_{\text{ref.}} = (\text{COP})_{\text{H.P.}} - 1$$

$$\text{or } 6 = \frac{H}{W} \quad \therefore (\text{COP})_{\text{H.P.}} = 6$$

$$\text{So input (W)} = \frac{H}{6}$$

But motor efficiency 90% so

$$\text{Electrical energy require (E)} = \frac{W}{0.9} = \frac{H}{0.9 \times 6}$$

$$= 0.1852 H$$

$$= 18.52\% \text{ of Heat (direct heating)}$$

$$H = \frac{100}{18.52} \frac{\text{kW}}{\text{kW of work}} = 5.3995 \text{ kW}$$

EXAMPLE Calculate the entropy change when 1 kg nitrogen is changed from 300 K and 1 bar to 500 K and 3 bar. For nitrogen, $C_p = 1.0416 \text{ kJ/kg K}$. Assume that nitrogen behaves like an ideal gas.

SOLUTION The entropy change of an ideal gas is given by

$$\Delta s = C_p \ln(T_2/T_1) - R \ln(P_2/P_1)$$

For nitrogen,

$$R = \frac{R_u}{M} = \frac{8.314 \times 10^3}{28}$$

$$= 0.2969 \text{ kJ/kg K}$$

Therefore,

$$\Delta s = 1.0416 \times 10^3 \ln(500/300) - 0.2969 \times 10^3 \ln(3/1)$$

$$= 0.2059 \text{ kJ/kg K}$$

Example

- (a) Air at 30 °C and 1 bar is compressed to a pressure of 5 bar in a SSSF reversible adiabatic process. It is then throttled back to the initial pressure of 1 bar. Show the two processes on $T-s$ and $p-v$ diagrams, and calculate the work done and net change in entropy of the universe per kg of air. Explain the significance of the result.
 - (b) If the air is now restored to the initial state completing a cycle, estimate the net work done and heat transfer. Assuming the temperature of the surroundings as 25 °C, determine the net change in the entropy of the universe for the complete cycle per kg of air, and explain the significance of the result.
- (a) The processes are shown in Fig. 6.56.

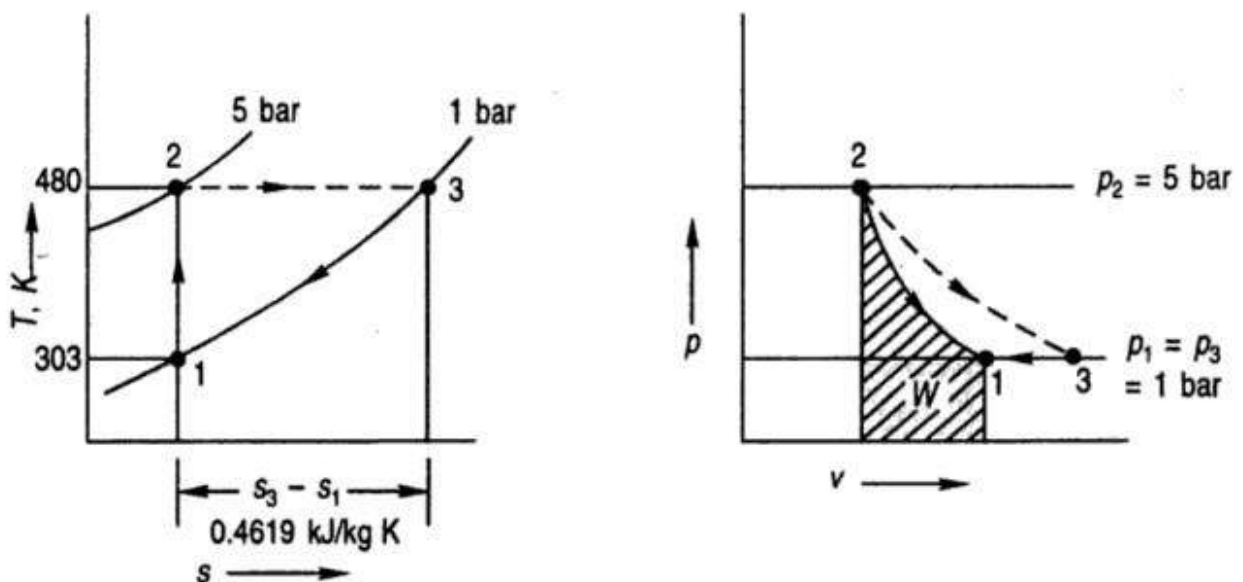

Fig. 6.56 Figure for Example 6.21

Temperature after reversible adiabatic compression

$$T_2 = T_1 \left(\frac{p_2}{p_1} \right)^{\frac{k-1}{k}} = 303 (5)^{0.2857} = 480 \text{ K (207 °C)}$$

$$T_2 = T_1 \left(\frac{P_2}{P_1} \right)^{\frac{k-1}{k}} = 303 (5)^{0.2857} = 480 \text{ K (207 } ^\circ\text{C)}$$

Work of reversible adiabatic compression

$${}_1w_2 = (h_2 - h_1) = C_{p0} (T_2 - T_1) = 1.0035 (480 - 313) = 177 \text{ kJ/kg}$$

Entropy change of air during compression, $s_2 - s_1$, is zero. Entropy change of air during throttling ($T_3 = T_2$) is

$$s_3 - s_2 = -R \ln \frac{P_3}{P_2} = -0.287 \ln \left(\frac{1}{5} \right) = 0.4619 \text{ kJ/kg K}$$

Net entropy change of air

$$s_3 - s_1 = s_3 - s_2 = 0.4619 \text{ kJ/kg K}$$

Entropy change of surroundings is zero since there is no heat transfer.

Net entropy change of universe

$$\Delta S_{\text{universe}} = \Delta S_{\text{air}} = 0.4619 \text{ kJ/kg K}$$

During reversible adiabatic compression, 177 kJ of work per kg of air was done by the surroundings on the control volume. During irreversible throttling process, pressure dropped back to 1 bar, and the volume increased without extracting any work from the control volume. Thus, the work done during the reversible adiabatic compression process 1-2 was wasted in the irreversible throttling process 2-3. Surroundings is, therefore, a loser of 177 kJ of work and the entropy of the universe increases by 0.4619 kJ/K per kg of air.

(b) If the air is restored from 3 to the initial state 1, the cycle is completed. Then, for the working substance

$$\Delta S_{\text{system}} = 0$$

Process 3 to 1 is a constant pressure cooling process. No work is done in this flow process since $-\int v dp = 0$. However, heat is rejected to the surroundings which is given by

$$\begin{aligned} {}_3q_1 &= C_{p0} (T_1 - T_3) = Q_{\text{surr}} \\ &= 1.0035 (480 - 303) = 177 \text{ kJ/kg} \end{aligned}$$

Increase in entropy of the surroundings

$$\Delta S_{\text{surr}} = \frac{Q}{T_0} = \frac{177}{298} = 0.594 \text{ kJ/K}$$

Increase in entropy of the universe

$$\Delta S_{\text{universe}} = \Delta S_{\text{system}} + \Delta S_{\text{surr}} = 0.594 \text{ kJ/K}$$

Thus, when the cycle is completed, the surroundings is a net loser of more valuable form of energy, that is, work of an amount equal to 177 kJ, and net gainer of waste heat of the same amount at the temperature of the surroundings itself. Further we see that the entropy of the universe increases by 0.594 kJ/kg K net as a result of the introduction of the irreversible throttling process.

Note: It is seen that the lost work is given by

$$LW = I = T_0 \delta S = 298(0.594) = 177 \text{ kJ}$$

Example 6.1 A cyclic heat engine operates between a source temperature of 800°C and a sink temperature of 30°C. What is the least rate of heat rejection per kW net output of the engine?

Solution For a reversible engine, the rate of heat rejection will be minimum (Fig. Ex. 6.1).

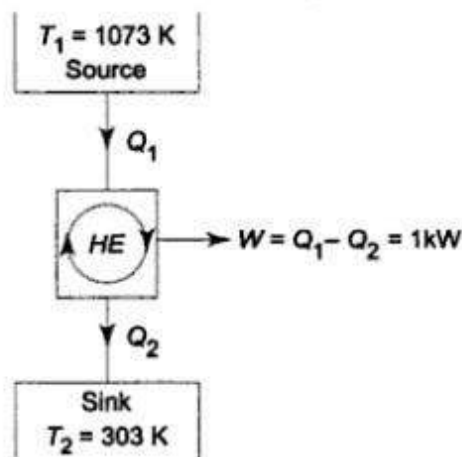

Fig. Ex. 6.1

$$\eta_{\text{max}} = \eta_{\text{rev}} = 1 - \frac{T_2}{T_1}$$

$$= 1 - \frac{30 + 273}{800 + 273}$$

$$= 1 - 0.282 = 0.718$$

Now $\frac{W_{\text{net}}}{Q_1} = \eta_{\text{max}} = 0.718$

$\therefore Q_1 = \frac{1}{0.718} = 1.392 \text{ kW}$

Now $Q_2 = Q_1 - W_{\text{net}} = 1.392 - 1$
 $= 0.392 \text{ kW}$

This is the least rate of heat rejection.

Which is the more effective way to increase the efficiency of a Carnot engine: to increase T_1 , keeping T_2 constant; or to decrease T_2 , keeping T_1 constant?

Solution The efficiency of a Carnot engine is given by

$$\eta = 1 - \frac{T_2}{T_1}$$

If T_2 is constant

$$\left(\frac{\partial \eta}{\partial T_1} \right)_{T_2} = \frac{T_2}{T_1^2}$$

As T_1 increases, η increases, and the slope $\left(\frac{\partial \eta}{\partial T_1} \right)_{T_2}$ decreases (Fig. Ex. 6.4.1).

If T_1 is constant,

$$\left(\frac{\partial \eta}{\partial T_2} \right)_{T_1} = - \frac{1}{T_1}$$

As T_2 decreases, η increases, but the slope $\left(\frac{\partial \eta}{\partial T_2} \right)_{T_1}$ remains constant (Fig. Ex. 6.4.2).

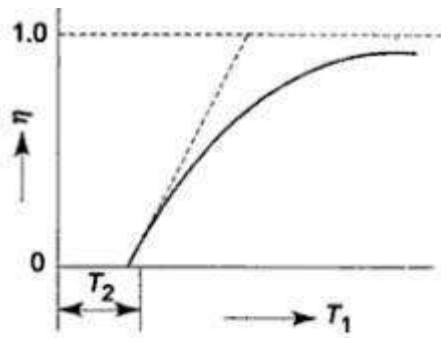

Fig. Ex. 6.4.1

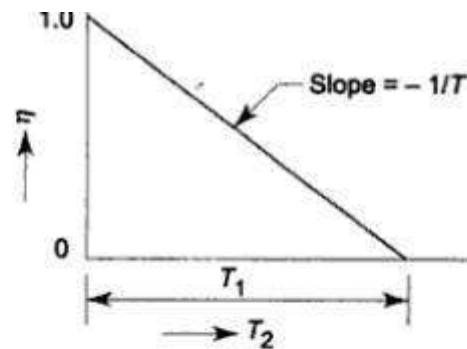

Fig. Ex. 6.4.2

Also
$$\left(\frac{\partial \eta}{\partial T_1}\right)_{T_2} = \frac{T_2}{T_1^2} \text{ and } \left(\frac{\partial \eta}{\partial T_2}\right)_{T_1} = -\frac{T_1}{T_1^2}$$

Since
$$T_1 > T_2, \left(\frac{\partial \eta}{\partial T_2}\right)_{T_1} > \left(\frac{\partial \eta}{\partial T_1}\right)_{T_2}$$

So, the more effective way to increase the efficiency is to decrease T_2 .
Alternatively, let T_2 be decreased by ΔT with T_1 remaining the same

$$\eta_1 = 1 - \frac{T_2 - \Delta T}{T_1}$$

If T_1 is increased by the same ΔT , T_2 remaining the same

$$\eta_2 = 1 - \frac{T_2}{T_1 + \Delta T}$$

Then

$$\begin{aligned} \eta_1 - \eta_2 &= \frac{T_2}{T_1 + \Delta T} - \frac{T_2 - \Delta T}{T_1} \\ &= \frac{(T_1 - T_2)\Delta T + (\Delta T)^2}{T_1(T_1 + \Delta T)} \end{aligned}$$

Since $T_1 > T_2, (\eta_1 - \eta_2) > 0$

The more effective way to increase the cycle efficiency is to decrease T_2 .

Example A fluid undergoes a reversible adiabatic compression from 0.5 MPa, 0.2 m³ to 0.05 m³ according to the law, $pv^{1.3} = \text{constant}$. Determine the change in enthalpy, internal energy and entropy, and the heat transfer and work transfer during the process.

Solution

$$TdS = dH - Vdp$$

For the reversible adiabatic process (Fig. Ex. 7.7)

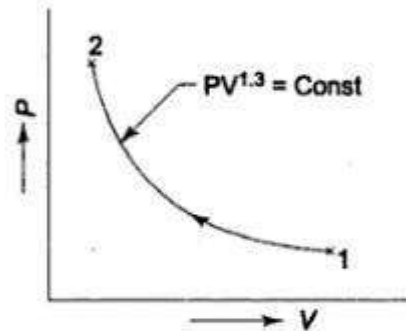

Fig. Ex. 7.7

$$dH = Vdp$$

$$p_1 = 0.5 \text{ MPa}, V_1 = 0.2 \text{ m}^3$$

$$V_2 = 0.05 \text{ m}^3, p_1 V_1^n = p_2 V_2^n$$

∴

$$p_2 = p_1 \left(\frac{V_1}{V_2} \right)^n$$

$$= 0.5 \times \left(\frac{0.20}{0.05} \right)^{1.3} \text{ MPa}$$

$$= 0.5 \times 6.061 \text{ MPa}$$

$$= 3.0305 \text{ MPa}$$

$$p_1 V_1^n = p V^n$$

$$V = \left(\frac{p_1 V_1^n}{p} \right)^{1/n}$$

$$\int_{H_1}^{H_2} dH = \int_{p_1}^{p_2} V dp$$

$$H_2 - H_1 = \int_{p_1}^{p_2} \left[\left(\frac{p_1 V_1^n}{p} \right)^{1/n} \right] dp$$

$$\begin{aligned}
 &= (p_1 V_1^n)^{1/n} \left(\frac{p_1^{1-1/n} - p_1^{1-n/n}}{1-1/n} \right) \\
 &= \frac{n(p_2 V_2 - p_1 V_1)}{n-1} \\
 &= \frac{1.3(3030.5 \times 0.05 - 500 \times 0.2)}{1.3-1} \\
 &= 223.3 \text{ kJ}
 \end{aligned}$$

$$\begin{aligned}
 H_2 - H_1 &= (U_2 + p_2 V_2) - (U_1 + p_1 V_1) \\
 &= (U_2 - U_1) + (p_2 V_2 - p_1 V_1)
 \end{aligned}$$

$$\begin{aligned}
 U_2 - U_1 &= (H_2 - H_1) - (p_2 V_2 - p_1 V_1) \\
 &= 223.3 - 51.53
 \end{aligned}$$

$$= 171.77 \text{ kJ}$$

Ans.

$$S_2 - S_1 = 0$$

Ans.

$$Q_{1-2} = 0$$

Ans.

$$Q_{1-2} = U_2 - U_1 + W_{1-2}$$

$$W_{1-2} = U_1 - U_2 = -171.77 \text{ kJ}$$

Ans.

Example Air is flowing steadily in an insulated duct. The pressure and temperature measurements of the air at two stations *A* and *B* are given below. Establish the direction of the flow of air in the duct. Assume that for air, specific heat c_p is constant at 1.005 kJ/kg K, $h = c_p T$, and $\frac{v}{T} = \frac{0.287}{p}$, where p , v and T are pressure (in kPa), volume (in m³/kg) and temperature (in K) respectively.

	Station A	Station B
Pressure	130 kPa	100 kPa
Temperature	50°C	13°C

Solution From property relation

$$Tds = dh - vdp$$

$$ds = \frac{dh}{T} - v \frac{dp}{T}$$

For two states at *A* and *B* the entropy change of the system

$$\int_{s_A}^{s_B} ds = \int_{T_A}^{T_B} \frac{c_p dT}{T} - \int_{p_A}^{p_B} 0.287 \frac{dp}{p}$$

$$\begin{aligned}
 \therefore s_B - s_A &= 1.005 \ln \frac{T_B}{T_A} - 0.287 \ln \frac{p_B}{p_A} \\
 &= 1.005 \ln \frac{273 + 13}{273 + 50} - 0.287 \ln \frac{100}{130}
 \end{aligned}$$

$$\begin{aligned}
 &= -0.1223 + 0.0753 \\
 &= -0.047 \text{ kJ/kg K} \\
 (\Delta S)_{\text{system}} &= -0.047 \text{ kJ/kg K}
 \end{aligned}$$

Since the duct is insulated $(\Delta S)_{\text{surr}} = 0$

$$(\Delta S)_{\text{univ}} = -0.047 \text{ kJ/kg K}$$

This is impossible. So the flow must be from *B* to *A*.

Example 7.9 A hypothetical device is supplied with 2 kg/s of air at 4 bar, 300 K. Two separate streams of air leave the device, as shown in figure below. Each stream is at an ambient pressure of 1 bar, and the mass flow rate is the same for both streams. One of the exit streams is said to be at 330 K while the other is at 270 K. The ambient temperature is at 300 K. Determine whether such a device is possible.

Solution The entropy generation rate for the control volume (Fig. Ex. 7.9) is

$$\begin{aligned}
 \dot{S}_{\text{gen}} &= \sum \dot{m}_e s_e - \sum \dot{m}_i s_i \\
 &= \dot{m}_2 s_2 + \dot{m}_3 s_3 - \dot{m}_1 s_1 \\
 &= \dot{m}_2 s_2 + \dot{m}_3 s_3 - (\dot{m}_2 + \dot{m}_3) s_1 \\
 &= \dot{m}_2 (s_2 - s_1) + \dot{m}_3 (s_3 - s_1)
 \end{aligned}$$

Now,

$$\begin{aligned}
 s_2 - s_1 &= c_p \ln \frac{T_2}{T_1} - R \ln \frac{p_2}{p_1} \\
 &= 1.005 \ln \frac{330}{300} - 0.287 \ln \frac{1}{4} \\
 &= 0.494 \text{ kJ/kgK}
 \end{aligned}$$

$$\begin{aligned}
 s_3 - s_1 &= c_p \ln \frac{T_3}{T_1} - R \ln \frac{p_3}{p_1} \\
 &= 1.005 \ln \frac{270}{300} - 0.287 \ln \frac{1}{4} \\
 &= 0.292 \text{ kJ/kgK}
 \end{aligned}$$

$$\begin{aligned}
 \dot{S}_{\text{gen}} &= 1 \times 0.494 + 1 \times 0.292 \\
 &= 0.786 \text{ kW/K}
 \end{aligned}$$

Since $\dot{S}_{\text{gen}} > 0$, the device is possible. Such devices actually exist and are called *vortex tubes*. Although they have low efficiencies, they are suitable for certain applications like rapid cooling of soldered parts, electronic component cooling, cooling of machining operations and so on. The vortex tube is essentially a passive device with no moving parts. It is relatively maintenance free and durable.

Example A room is maintained at 27°C while the surroundings are at 2°C. The temperatures of the inner and outer surfaces of the wall ($k = 0.71 \text{ W/mK}$) are measured to be 21°C and 6°C, respectively. Heat flows steadily through the wall 5 m × 7 m in cross-section and 0.32 m in thickness. Determine (a) the rate of heat transfer through the wall, (b) the rate of entropy generation in the wall, and (c) the rate of total entropy generation with this heat transfer process.

Solution

$$\begin{aligned}\dot{Q} &= k A \frac{\Delta T}{L} = 0.71 \frac{\text{W}}{\text{mK}} \times (5 \times 7) \text{m}^2 \times \frac{(21-6) \text{K}}{0.32 \text{ m}} \\ &= 1164.84 \text{ W} \quad \text{Ans. (a)}\end{aligned}$$

Taking the wall as the system, the entropy balance in rate form gives:

$$\begin{aligned}\frac{dS_{\text{wall}}}{dt} &= \dot{S}_{\text{transfer}} + \dot{S}_{\text{gen.wall}} \\ 0 &= \sum \frac{\dot{Q}}{T} + \dot{S}_{\text{gen.wall}} \\ 0 &= \frac{1164.84}{294} - \frac{1164.84}{279} + \dot{S}_{\text{gen.wall}}\end{aligned}$$

Rate of entropy generation in the wall

$$\dot{S}_{\text{gen.wall}} = 4.175 - 3.962 = 0.213 \text{ W/K} \quad \text{Ans. (b)}$$

The entropy change of the wall is zero during this process, since the state and hence the entropy of the wall does not change anywhere in the wall.

To determine the rate of total entropy generation during this heat transfer process, we extend the system to include the regions on both sides of the wall,

$$\begin{aligned}\frac{dS_{\text{total}}}{dt} &= \dot{S}_{\text{transfer}} + \dot{S}_{\text{gen.total}} \\ 0 &= \sum \frac{\dot{Q}}{T} + \dot{S}_{\text{gen.total}} \\ 0 &= \frac{1164.84}{300} - \frac{1164.84}{275} + \dot{S}_{\text{gen.total}} \\ \dot{S}_{\text{gen.total}} &= 4.236 - 3.883 = 0.353 \text{ W/K} \quad \text{Ans. (c)}\end{aligned}$$

Industry applications

- Automobile industries.
- Refrigeration industries
- Air craft applications
- Defense industries
- Thermal power plants etc.

Assignment questions

1. Describe briefly about the second law of thermodynamics with its corollaries.
2. State the limitations of first law of thermodynamics? State PMM 2?
3. Discuss briefly about Clausius inequality.
4. Discuss the significance of Third law of thermodynamics
5. A heat pump working on a reversed Carnot cycle takes in energy from a reservoir maintained at 30C and delivers it to another reservoir where temperature is 77C. The heat pump drives power for its operation from a reversible engine operating within the higher and lower temperature limits of 1077C and 77C. For 100 kJ/sec of energy supplied to the reservoir at 77C, estimate the energy taken from the reservoir at 1077C.
6. Derive the expression for the efficiency of Carnot cycle with p-V and T-s diagrams.
7. Solve one T -dS equation by using Maxwell's relations?

Tutorial questions

1. 0.5 kg of air executes a Carnot power cycle having a thermal efficiency of 50%. The heat transfer to the air during isothermal expansion is 40 kJ. At the beginning of the isothermal expansion the pressure is 7 bar and the volume is 0.12 m³. Determine the maximum and minimum temperatures for the cycle in Kelvin, the volume at the end of isothermal expansion in m³ and the work, heat transfer for each of the four processes in kJ. $c_p=1.008$ kJ/kgK and $c_v=0.721$ kJ/kgK for air.
2. Water is heated at a constant pressure of 0.7 MPa. The boiling point is 164.970C. The initial temperature of water is 00C. The latent heat of evaporation is 2066.3 kJ/kg. Find the increase of entropy of water if the final temperature is steam.
3. 1kg of ice at -50C expose to the atmosphere which, is at 200C. The ice melts and comes into thermal equilibrium with the atmosphere. Determine the entropy increase of Universe. C_p for ice is 2.039 kJ/kgK, and the enthalpy of fusion of ice is 333.3kJ/kg.
4. A heat engine is operating between two reservoirs 1000K and 300K is used to drive a heat pump which extracts heat from the reservoir at 300K at arate twice that at which the engine rejects the heat to it. If the efficiency of the engine is 40% of the maximum possible and COP of heat pump is 50% of the maximum possible, then determine the temperature of the reservoir to which the heat pump rejects heat. Also determine the rate of heat rejection from the heat pump, if the rate of heat supply to the heat engine is 50kW?
5. A heat engine is operating between two reservoirs 1000K and 300K is used to drive a heat pump which extracts heat from the reservoir at 300K at A heat engine is operating between two reservoirs 1000K and 300K is used to drive a heat pump which extracts heat from the reservoir at 300K. The efficiency of both the engines is equal. What is the value of temperature T2.

UNIT -III

Properties of pure substances:

Pure substance

A substance that has a fixed chemical composition throughout the system is called a pure substance. Water, hydrogen, nitrogen, and carbon monoxide, for example, are all pure substance. A pure substance can also be a mixture of various chemical elements or compounds as long as the mixture is homogeneous. Air, a mixture of several compounds, is often considered to be a pure substance because it has a uniform chemical composition. "A mixture of two or more phases of a pure substance is still a pure substance as long as the chemical composition of all phases is the same. A mixture of ice and liquid water, for example, is a pure substance because both phases have the same chemical composition."

PVT Surface

Pressure can be expressed as a function of temperature and specific volume: $p = p(T, v)$. The plot of $p = p(T, v)$ is a surface called p - v - T surface. Figure 3.1 shows the p - v - T surface of a substance such as water that expands on freezing.

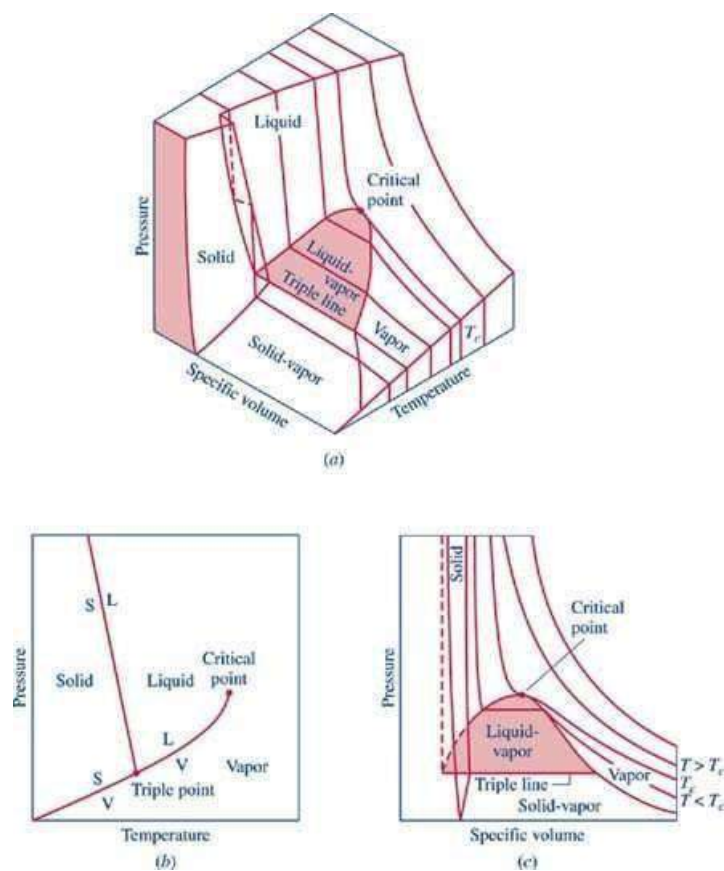

Figure 3.1 p - v - T surface and projections for a substance that expands on freezing.

(a) 3-D view (b) p - T diagram (c) p - v diagram².

The location of a point on the p - v - T surface gives the values of pressure, specific volume, and temperature at equilibrium. The regions on the p - v - T surface labeled *solid*, *liquid*, and *vapor* are single-phase regions. The state of a single phase is determined by any two of the properties: pressure, temperature, and specific volume. The two-phase regions where two phases exist in equilibrium separate the single-phase regions. The two-phase regions are: liquid-vapor, solid-liquid, and solid-vapor. Temperature and pressure are dependent within the two-phase regions. Once the temperature is specified, the pressure is determined and vice versa. The states within the two-phase regions can be fixed by specific volume and either temperature or pressure.

The projection of the p - v - T surface onto the p - T plane is known as the phase diagram as shown in Figure 3.1 (b). The two-phase regions of the p - v - T surface reduce to lines in the phase diagram. A point on any of these lines can represent any two-phase mixture at that particular temperature and pressure. The triple line of the p - v - T surface projects onto a point on the phase diagram called the triple point. Three phases coexist on the triple line or the triple point.

The constant temperature lines of the p - v diagram are called the isotherms. For any specified temperature less than the critical temperature, the pressure remains constant within the two-phase region even though specific volume changes. In the single-phase liquid and vapor regions the pressure decreases at fixed temperature as specific volume increases. For temperature greater than or equal to the critical temperature, there is no passage across the two-phase liquid-vapor region.

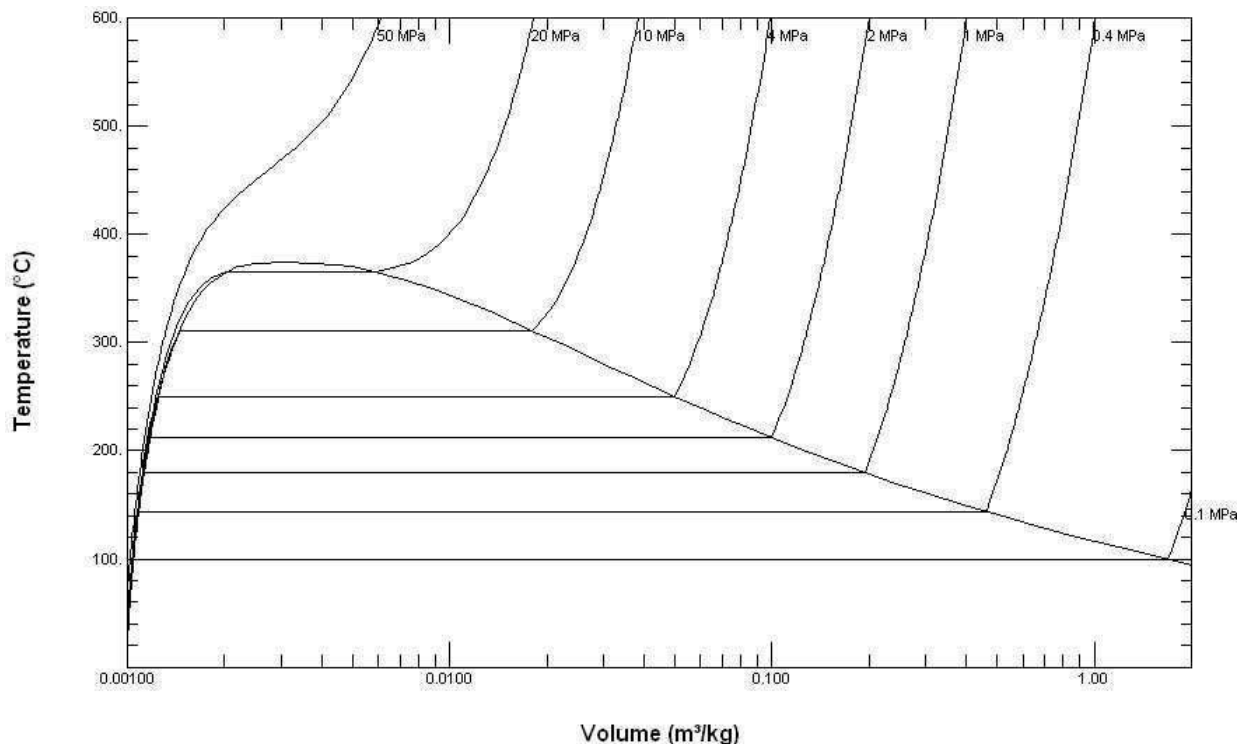

Figure 3.1-2 T - v diagram for water (to scale).

Figure 3.1-2 is a $T-v$ diagram for water. For pressure greater than or equal to the critical pressure, temperature increases continuously at fixed pressure as the specific volume increases and there is no passage across the two-phase liquid-vapor region. The isobaric curve marked 50 MPa in Figure 3.1-2 shows this behavior. For pressure less than the critical value, there is a two-phase region where the temperature remains constant at a fixed pressure as the two-phase region is traversed. The isobaric curve with values of 20 MPa or less in Figure 3.1-2 shows the constant temperature during the phase change.

At 100°C, the saturated volumes of liquid and vapor water are 1.0434 cm³/g and 1,673.6 cm³/g, respectively. The quality of steam is the mass fraction of water vapor in a mixture of liquid and vapor water. The specific volume of 100°C steam with a quality of 0.65 is given by

$$v = (1 - 0.65)v^l + 0.65 v^v = (0.35)(1.0434) + (0.65)(1,673.6) = 1088.2 \text{ cm}^3/\text{g}$$

Phase Behavior:

We will consider a phase change of 1 kg of liquid water contained within a piston-cylinder assembly as shown in Figure 3.2-1a. The water is at 20°C and 1.014 bar (or 1 atm) as indicated by point (1) on Figure 3.2-2.

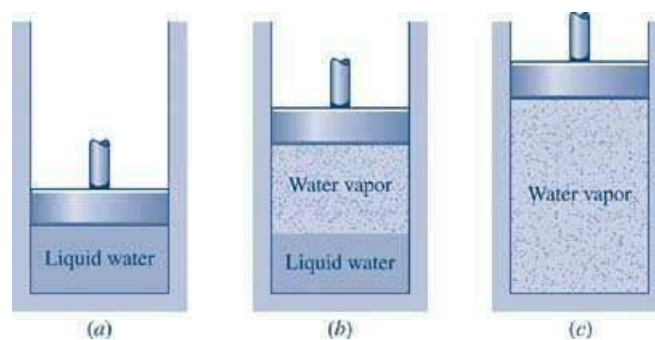

Figure 3.2-1 Phase change at constant pressure for water³

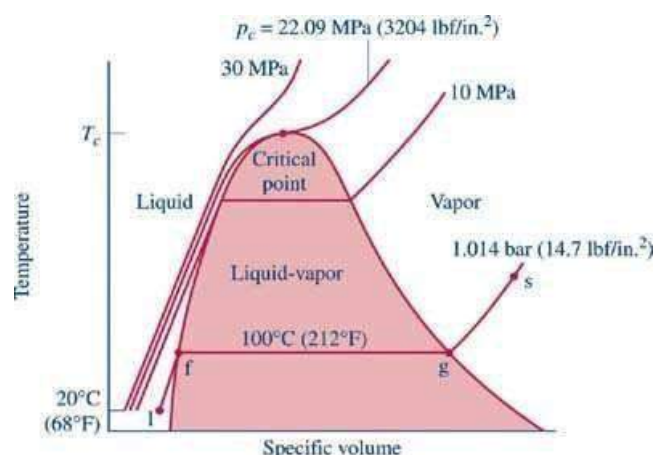

Figure 3.2-2 Sketch of $T-v$ diagram for water

As the water is heated at constant pressure, the temperature increases with a slight increase in specific volume until the system reaches point (f). This is the

saturated liquid state corresponding to 1.014 bar. The saturation temperature for water at 1.014 bar is 100°C. The liquid states along the line segment 1-f are called *subcooled* or *compressed* liquid states. When the system is at the saturated liquid state (point f in Figure 3.2-2) any additional heat will cause the liquid to evaporate at constant pressure as shown in Figure 3.2-1b. When a mixture of liquid and vapor exists in equilibrium, the liquid phase is a saturated liquid and the vapor phase is a saturated vapor.

Liquid water continues to evaporate with additional heat until it becomes all saturated vapor at point (g). Any further heating will cause an increase in both temperature and specific volume and the saturated vapor becomes superheated vapor denoted by point (s) in Figure 3.2-2. For a two-phase liquid-vapor mixture, the quality x is defined as the mass fraction of vapor in the mixture

$$x = \frac{m_{\text{vapor}}}{m_{\text{vapor}} + m_{\text{liquid}}}$$

When a substance exists as part liquid and part vapor at saturation conditions, its quality (x) is defined as the ratio of the mass of the vapor to the total mass of both vapor and liquid.

Enthalpy–Entropy Chart

An enthalpy–entropy chart, also known as the H–S chart or Mollier diagram, plots the total heat against entropy, describing the enthalpy of a thermodynamic system. A typical chart covers a pressure range of 0.01–1000 bar, and temperatures up to 800 degrees Celsius. It shows enthalpy H in terms of internal energy U , pressure p and volume V using the relationship $H=U+pV$ or, in terms of specific enthalpy, specific entropy and specific volume.

On the diagram, lines of constant pressure, constant temperature and volume are plotted, so in a two-phase region, the lines of constant pressure and temperature coincide. Thus, coordinates on the diagram represent entropy and heat.

A vertical line in the h – s chart represents an isentropic process. The process 3–4 in a Rankine cycle is isentropic when the steam turbine is said to be an ideal one. So the expansion process in a turbine can be easily calculated using the h – s chart when the process is considered to be ideal (which is the case normally when calculating enthalpies, entropies, etc. Later the deviations from the ideal values and they can be calculated considering the isentropic efficiency of the steam turbine used.

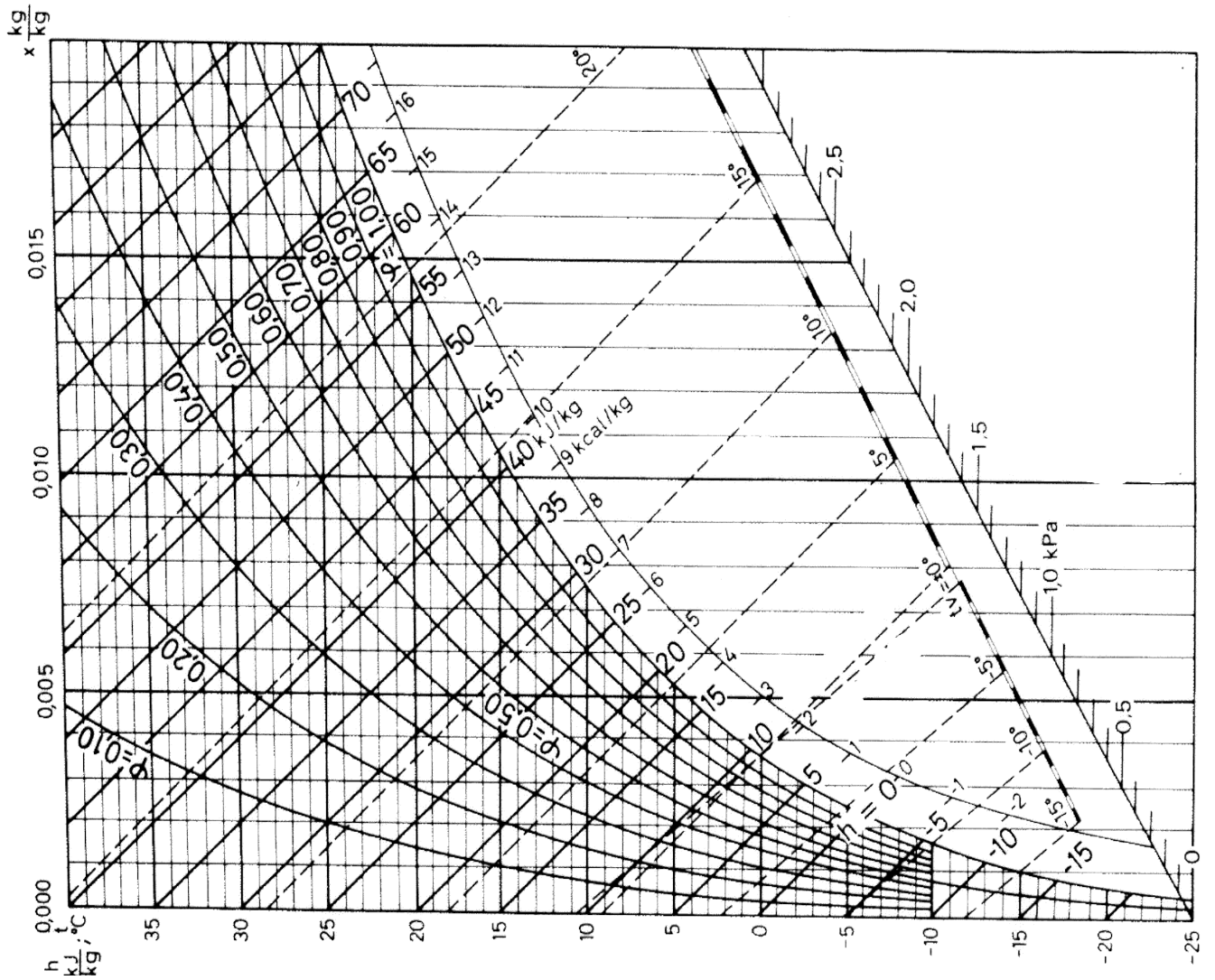

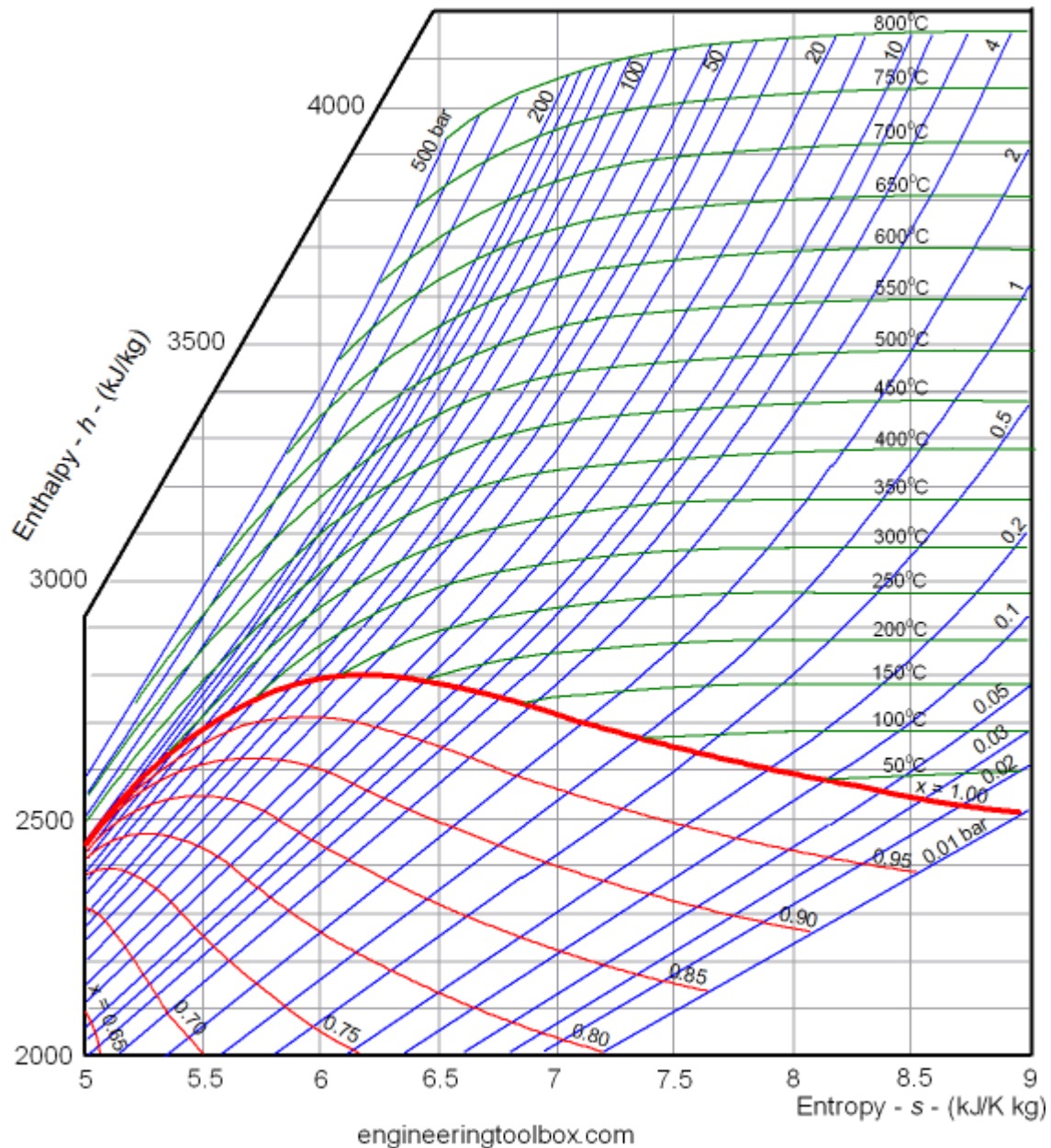

Lines of constant dryness fraction (x), sometimes called the quality, are drawn in the wet region and lines of constant temperature are drawn in the superheated region. x gives the fraction (by mass) of gaseous substance in the wet region, the remainder being colloidal liquid droplets. Above the heavy line, the temperature is above the boiling point, and the dry (superheated) substance is gas only.

Characteristics of the critical point:

- For saturated phase often its enthalpy is an important property.
- Enthalpy-pressure charts are used for refrigeration cycle analysis.
- Enthalpy-entropy charts for water are used for steam cycle analysis.
- Note: Unlike pressure, volume and temperature which have specified numbers associated with it, in the case of internal energy, enthalpy (and entropy) only changes are required. Consequently, a base (or datum) is defined -as you have seen in the case of water.

Let V be total volume of liquid vapour mixture of quality x , V_f the volume of saturated liquid and V_g the volume of saturated vapour, the corresponding masses being m , m_f and m_g respectively.

Now, $m = m_f + m_g$

$V = V_f + V_g$

$m v = m_f v_f + m_g v_g$

Saturation States

When a liquid and its vapour are in equilibrium at certain pressure and temperature, only the pressure or the temperature is sufficient to identify the saturation state.

If pressure is given, the temperature of the mixture gets fixed, which is known as saturation temperature, or if the temperature is given, the saturation pressure gets fixed.

Saturation liquid or saturated vapour has only one independent variable, i.e. only one property is required to be known to fix up the state.

Type of Steam

Wet steam:

Wet steam is defined as steam which is partly vapour and partly liquid suspended in it. It means that evaporation of water is not complete.

Dry saturated steam:

When the wet steam is further heated, and it does not contain any suspended particles of water, it is known as dry saturated steam.

Superheated steam: When the dry steam is further heated at constant pressure, thus raising its temperature, it is called superheated steam.

Measurement of Steam Quality:

The state of a pure substance gets fixed if two independent properties are given. A pure substance is thus said to have two degrees of freedom. Of all thermodynamic properties, it is easiest to measure the pressure and temperature of a substance. Therefore, whenever pressure and temperature are independent properties, it is the practice to measure them to determine that state of the substance.

Types of Calorimeters used for measurement of Steam Quality

- Barrel Calorimeter
- Separating Calorimeter
- Throttling Calorimeter
- Combined Separating and Throttling calorimeter

Barrel Calorimeter

Dryness fraction of steam can be found out very conveniently by barrel calorimeter as shown in figure. A vessel contains a measured quantity of water. Also water equivalent of

the vessel is determined experimentally and stamped platform of weighing machine. Sample of steam is passed through the sampling tube into fine exit holes for discharge of steam in the cold water.

The steam gets condensed and the temperature of water rises. The weighing machine gives the steam condensed.

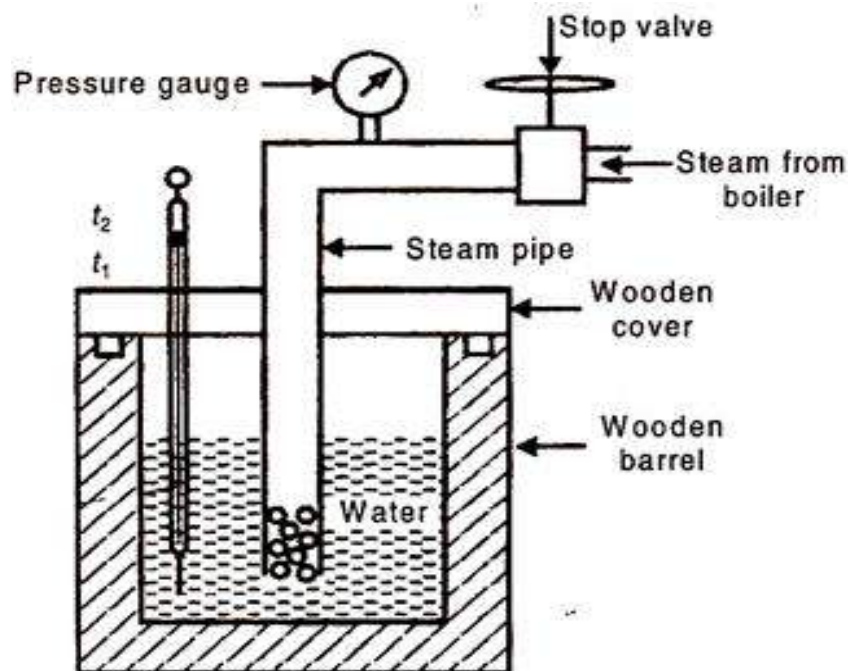

Fig. 10.19

Let,

- ms = weight of steam condensed
- m_w = weight of cold water in barrel
- C_{pw} = sp. heat of water
- x = dryness fraction of steam
- h_{fg} = latent heat of the steam at pressure of steam P
- t_1 = initial temperature of water before mixing steam
- t_2 = final temperature of steam after mixing of steam
- t = saturation the temperature of steam at P .

Then we can find the dryness fraction of steam by using the equations given below.

$$[\text{Heat lost by steam}] = [\text{Heat gained by coal water}]$$

$$Ms [x \cdot h_{fg} + C_{pw}(t - t_2)] = M_w C_{pw}(t_2 - t_1)$$

From this equation, we can find the dryness fraction of steam (x)

Basically, this calorimeter is used when we want to know the approximate dryness fraction of steam, or to have a rough idea about the dryness fraction. This calorimeter gives better results if the dryness fraction of steam is greater than 0.95.

Separating Calorimeter

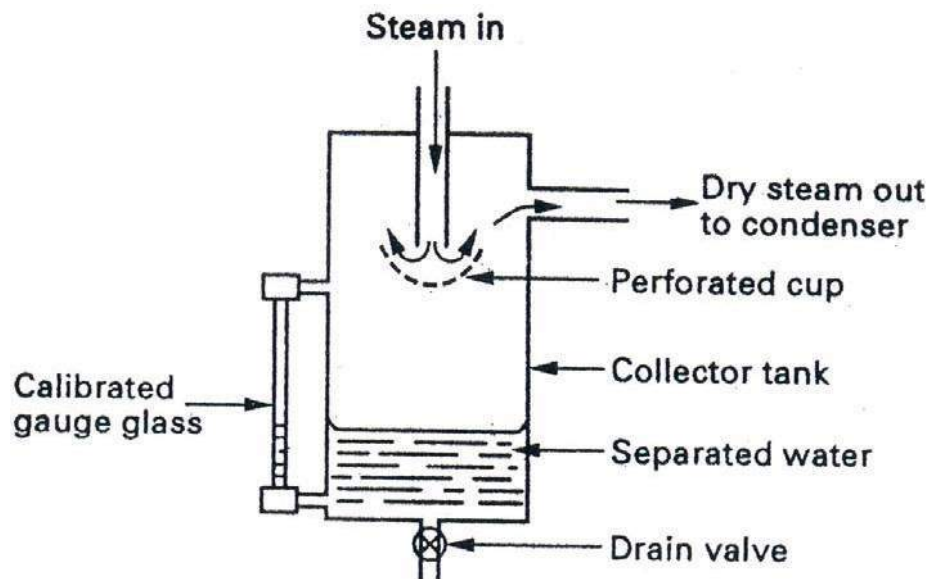

The wet steam enters at the top from the main steam pipe through holes in the sampling pipe facing up stream which should be as far as possible downstream from elbows and valves to ensure representative sample of steam when in operation the wet steam entering passes down the central passage and undergoes a sudden reversal of direction of motion when strikes perforated cup.

The weight of steam passing through the jacket may also be readily determined by passing the escaping steam into a bucket of water where it is condensed, the increase in the weight of the bucket and its contents giving the value of W . In that case gauge G is not required, but its reading may be taken as a check.

This calorimeter will give better results when the dryness fraction of steam to be determined is above 0.95.

Advantages:

Quick determination of dryness fraction of very wet steam

Disadvantages:

It leads to inaccuracy due to incomplete separation of water

Dryness fraction calculated is always greater than actual dryness fraction.

Throttling Calorimeter

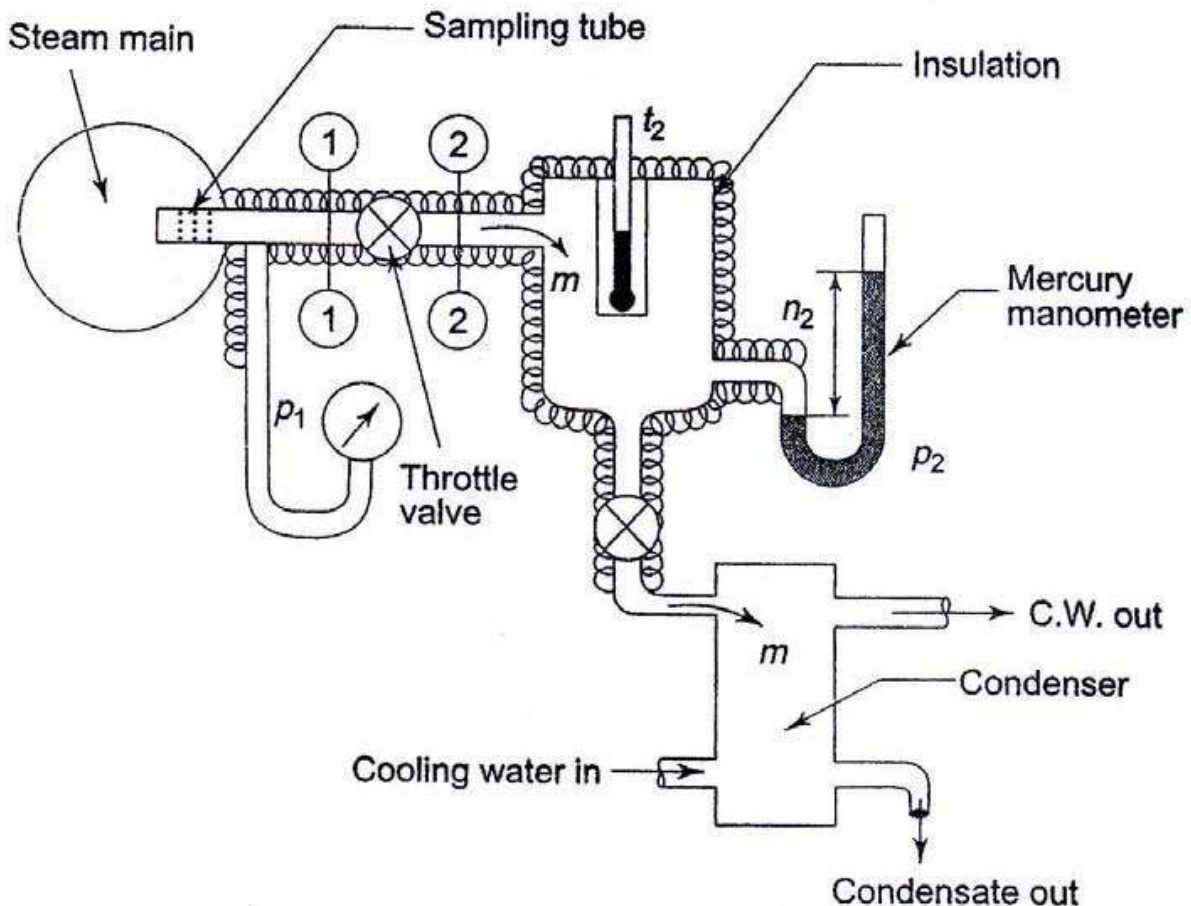

In the throttling calorimeter, a sample of wet steam of mass m and at pressure P_1 is taken from the steam main through a perforated sampling tube. Then it is throttled by the partially-opened valve (or orifice) to a pressure P_2 measured by mercury manometer, and temperature t_2 , so that after throttling the steam is in the superheated region.

The steady flow energy equation gives the enthalpy after throttling as equal to enthalpy before throttling. The initial and final equilibrium states 1 and 2 are joined by a dotted line since throttling is irreversible (adiabatic but not isentropic) and the intermediate states are non-equilibrium states not describable by thermodynamic coordinates. The initial state (wet) is given by P_1 and x_1 and the final state by P_2 and t_2 .

Advantages:

Dryness fraction of very dry steam can be found out easily.

Disadvantages:

It is not possible to find dryness fraction of very wet steam.

Combined Separating and Throttling calorimeter

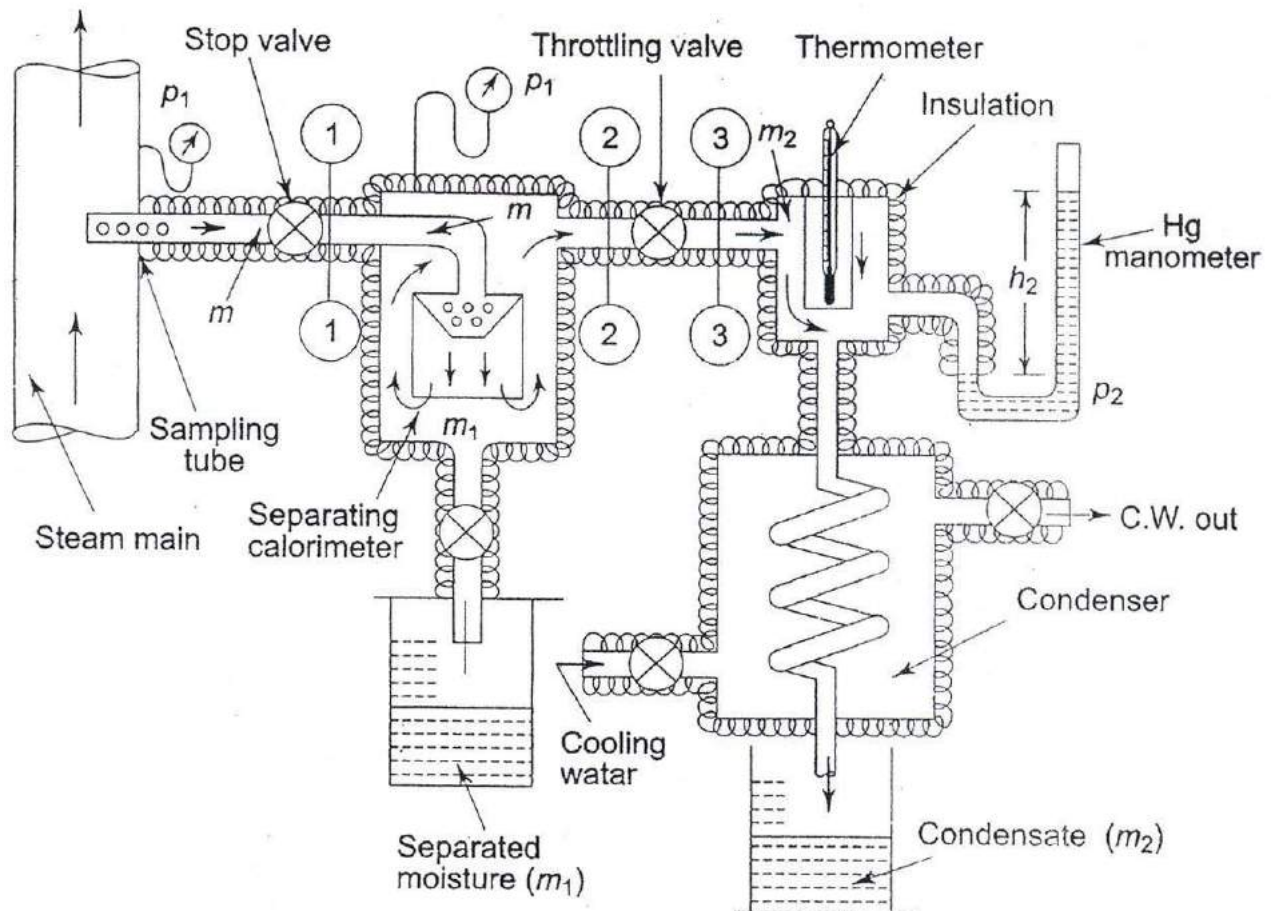

When the steam is very wet and the pressure after throttling is not low enough to take the steam to the superheated region, then a combined separating and throttling calorimeter is used for the measurement of quality.

Steam from the main is first passed through a separator where some part of the moisture separates out due to the sudden change in direction and falls by gravity, and the partially dry vapour is then throttled and taken to the superheated region.

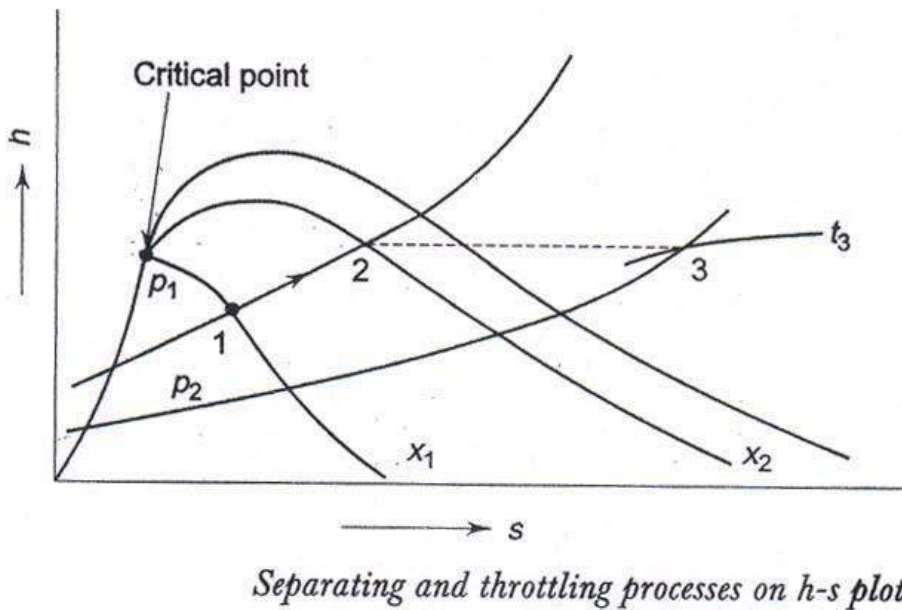

In Fig. process 1-2 represents the moisture separation from the wet sample of steam at constant pressure P1 and process 2-3 represents throttling to pressure P2. With P2 and t3 being measured, h3 can be found out from the superheated steam table.

$$h_3 = h_2 = h_{f p_1} + x_2 h_{fg p_1}$$

Therefore x2, the quality of steam after partial moisture separation can be evaluated. If m kg of steam, is taken through the sampling tube in t s, m1 kg of it is separated, and m2 kg is throttled and then condensed to water and collected, then m = m1 + m2 and at state 2, the mass of dry vapour will be x2 m2. Therefore, the quality of the sample of steam at state 1, x1 is given by . .

$$x_1 = \frac{\text{mass of dry vapour state 1}}{\text{mass of liquid - vapour mixture at state 1}} = \frac{m_2}{m_1 + m_2}$$

Mass of water (m_f) = 1.5 kg

Mass of steam (m_g) = 50 kg

Required : Dryness fraction (x) Solution

$$\text{Dryness fraction } (x) = \frac{m}{m_g + m_f}$$

$$= \frac{50}{50 + 1.5} = 0.971 \text{---- Ans}$$

Eg. Steam is generated at 8 bar from water at 32°C. Determine the heat required to produce 1 kg of steam (a) when the dryness fraction is 0.85 (b) when steam is dry saturated and (c) when the steam is superheated to 305°C. The specific heat of superheated steam may be taken as 2.093 kJ/kg-K.

Given:

Steam pressure (p) = 8 bar

Initial temperature of water (T_1) = 32°C Mass of steam (m) = 1 kg

Required: Heat required when (a) $x =$

0.85 (b) $x = 1$ (c) $T_{sup} = 305^\circ\text{C}$

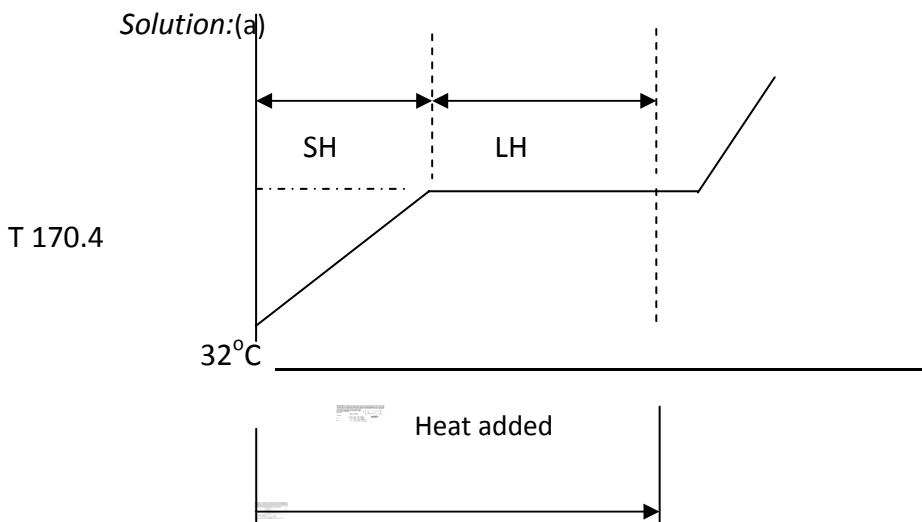

Heat required = Sensible heat addition + Latent

heat addition Sensible heat addition = $m C_{pw} (t_s - T_1)$

t_s = saturation temperature = 170.4°C at 8 bar

from steam table C_{pw} = Specific heat at constant

pressure = 4.186 kJ/kg (Taken)

$$\begin{aligned}\text{Sensible Heat addition} &= 1 \times 4.186 \times (170.4 - 32) \\ &= 79.34 \text{ kJ/kg}\end{aligned}$$

$$\text{Latent heat addition / kg} = x h_{fg}$$

$$\text{Latent heat } (h_{fg}) = 2046.5 \text{ kJ/kg from steam table at 8 bar}$$

$$\text{Latent heat addition for 'm' kg} = m \times h_{fg}$$

$$= 1 \times 0.85 \times (2046.5)$$

$$= 1739.525 \text{ kJ/kg}$$

$$\text{Total heat required} = 579.34 + 1739.525$$

$$= 2318.865 \text{ kJ/kg --- Ans}$$

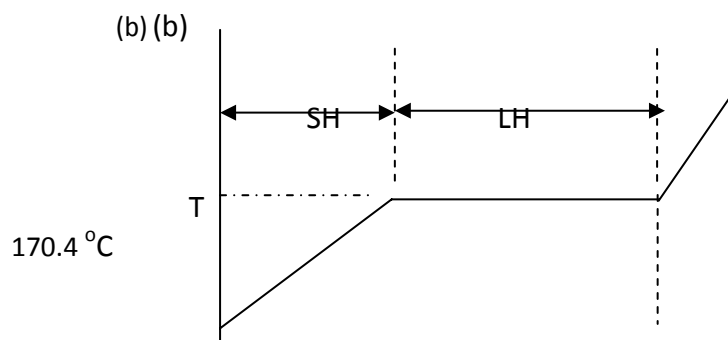

Heat required = Sensible heat addition + Latent heat addition
 $\text{Latent heat addition / kg} = x h_{fg}$

$$\text{Latent heat } (h_{fg}) = 2046.5 \text{ kJ/kg from steam}$$

$$\text{table at 8 bar Latent heat addition for 'm' kg} = m \times$$

$$h_{fg}$$

$$= 1 \times 1 \times (2046.5)$$

$$= 2046.5 \text{ kJ/kg}$$

$$\text{Total heat required} = 579.34 + 2046.5$$

$$= \mathbf{2625.84 \text{ kJ/kg --- Ans}}$$

Heat required = Sensible heat addition + Latent heat addition + Sensible

Heat addition Sensible heat addition to superheated steam

$$= m C_{pv} (T_{sup} - t_s)$$

$$= 1 \times 2.093 \times (305 - 170.4)$$

$$= 281.72 \text{ kJ/kg}$$

$$\text{Latent heat addition / kg} = h_{fg}$$

Latent heat (h_{fg}) = 2046.5 kJ/kg from steam table at 8 bar

Total heat required = 579.34 + 2046.5 + 281.72

= **2907.56 kJ/kg --- Ans**

Ideal Gas:

Perfect gas, also called ideal gas, a gas that conforms, in physical behaviour, to a particular, idealized relation between pressure, volume, and temperature called the general gas law.

Gas Laws:

Boyle's Law

Boyle's Law Pressure is inversely proportional to volume: $p \propto 1/v$ Robert Boyle noticed that when the volume of a container holding an amount of gas is increased, pressure decreases, and vice versa (while the temperature is held constant). Note that this is not a linear relationship between p and V .

Charles' Law:

Charles' Law Volume is directly proportional to temperature: $V = cT$, where $c > 0$ is constant. Scientist Jacque Charles noticed that if air in a balloon is heated, the balloon expands. For an ideal gas, this relationship between V and T should be linear (as long as pressure is constant).

Charles' and Boyle's Laws combined

Combine the two laws above: $pV/T = K$, where k is a constant, = $pV=mRT$

The Individual Gas Constant - R

The Individual Gas Constant depends on the particular gas and is related to the molecular weight of the gas. The value is independent of temperature. The individual gas constant, R , for a gas can be calculated from the universal gas constant, R_u (given in several units below), and the gas molecular weight, M_{gas} :

$$R = R_u/M_{gas}$$

In the SI system units are J/kg K.

The Universal Gas Constant - R_u

The Universal Gas Constant - R_u - appears in the ideal gas law and can be expressed as the product between the Individual Gas Constant - R - for the particular gas - and the Molecular Weight - M_{gas} - for the gas, and is the same for all ideal or perfect gases:

$$R_u = M_{gas} R, \text{ kJ}/(\text{kmol.K}) : 8.3144598$$

The Molecular weight of a Gas Mixture

The average molecular weight of a gas mixture is equal to the sum of the mole fractions of each gas multiplied by the molecular weight of that particular gas:

$$M_{\text{mixture}} = \sum x_i M_i = (x_1 M_1 + \dots + x_n M_n)$$

where

x_i = mole fractions of each gas

M_i = the molar mass of each gas

Throttling Process:

The porous plug experiment was designed to measure temperature changes when a fluid flows steadily through a porous plug which is inserted in a thermally insulated, horizontal pipe. The apparatus used by Joule and Thomson is shown in Figure

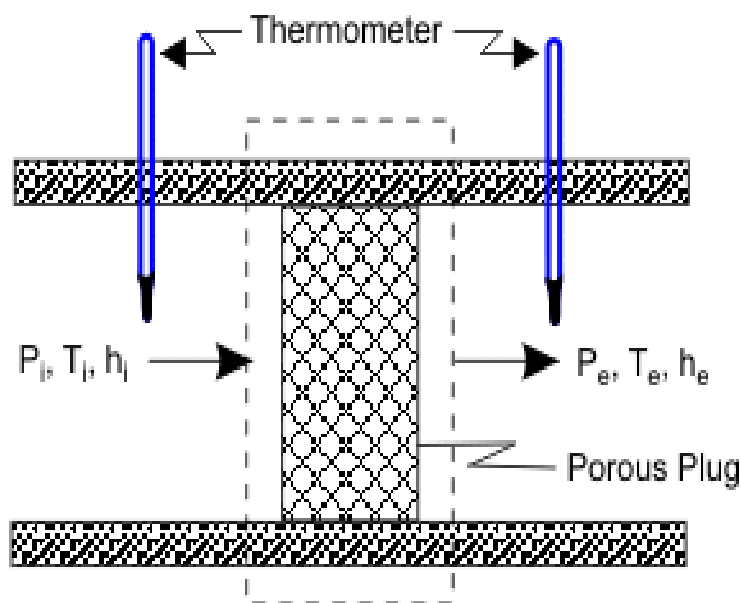

A gas at pressure and temperature flows continuously through a porous plug in a tube and emerges into a space which is maintained at a constant pressure. The device is thermally insulated and kept horizontal. Consider the dotted portion as control volume.

$$\dot{Q} = 0, W_{sh} = 0.$$

These results in $h_i = h_e$

Therefore, whenever a fluid expands from a region of high pressure to a region of low pressure through a porous plug, partially opened valve or some obstruction, without exchanging any energy as heat and work with the surrounding (neglecting, the changes in PE and KE), the enthalpy of the fluid remains constant, and the fluid is said to have undergone a throttling process.

Free expansion (or unresisted expansion) process. A free expansion occurs when a fluid is allowed to expand suddenly into a vacuum chamber through an orifice of large dimensions. In this process, no heat is supplied or rejected and no external work is done. Hence the total heat of the fluid remains constant. This type of expansion may also be called as constant total heat expansion. It is thus obvious, that in a free expansion process,

$Q_{1-2} = 0$, $W_{1-2} = 0$ and $dU = 0$.

van der Waals Equation of State:

The ideal gas law treats the molecules of a gas as point particles with perfectly elastic collisions. This works well for dilute gases in many experimental circumstances. But gas molecules are not point masses, and there are circumstances where the properties of the molecules have an experimentally measurable effect. A modification of the ideal gas law was proposed by Johannes D. van der Waals in 1873 to take into account molecular size and molecular interaction forces. It is usually referred to as the van der Waals equation of state.

$$\left[P + a \left(\frac{n}{V} \right)^2 \right] \left(\frac{V}{n} - b \right) = RT$$

The constants a and b have positive values and are characteristic of the individual gas. The van der Waals equation of state approaches the ideal gas law $PV=nRT$ as the values of these constants approach zero. The constant a provides a correction for the intermolecular forces. Constant b is a correction for finite molecular size and its value is the volume of one mole of the atoms or molecules.

Since the constant b is an indication of molecular volume, it could be used to estimate the radius of an atom or molecule, modeled as a sphere. Fishbane et al. give the value of b for nitrogen gas as $39.4 \times 10^{-6} \text{ m}^3/\text{mol}$.

Assignment Questions

1. Draw the phase equilibrium diagram for a pure substance on T-s plot with relevant constant property line?
2. 10 kg of feed water is heated in a boiler at a constant pressure of 1.5 MN/m² from 40 C. Calculate the enthalpy required and change of entropy when water is converted into following qualities of steam in each case i) Wet steam at x=0.95 and ii) Super heated steam at 300 C
3. Define dryness fraction of steam. Describe method of finding dryness fraction of steam using separating and throttling calorimeter
4. A rigid close tank of volume 3m³ contains 5 kg of wet steam at a pressure of 200 kPa. The tank is heated until the steam becomes dry saturated. Determine final pressure and heat transfer to the tank.
5. Describe briefly about throttling and free expansion processes.
6. Describe briefly about "Mollier diagram".
7. State Vander Waals equation, what is the importance of it?

Tutorial Questions

1. Determine the enthalpy and entropy of steam and the pressure is 2MPa and the specific volume is 0.09m³/kg.
2. 10 kg of feed water is heated in a boiler at a constant pressure of 1.5 MN/m² from 40 C. Calculate the enthalpy required and change of entropy when water is converted into following qualities of steam in each case i) Wet steam at x=0.95 and ii) Super heated steam at 300 C
3. Air at 16°C and 1.2 bar occupies a volume of 0.03m³.the air is heated at constant volume until the pressure is 4.3 bar and then cooled at constant pressure back to the original temperature. Calculate the net heat flow to or from the air and the net entropy change.
4. 5 kg of steam with a dryness fraction of 0.9 expands adiabatically to the Law $PV^{1.13}$ constant. from a pressure of 8 bar to 1.5 bar determine final dryness fraction ii)heat transferred iii)work done
5. A vessel of 0.04 m² Contains a mixture of saturated water and saturated steam at a temperature of 250°C. The Mass liquid present is 9kg . Find pressure, the mass, the specific volume, the enthalpy and entropy and the internal energy.

UNIT-IV

Mixtures of perfect Gases:

A mixture, consisting of several pure substances, is referred to as a solution. Examples of pure substances are water, ethyl alcohol, nitrogen, ammonia, sodium chloride, and iron. Examples of mixtures are air, consisting of nitrogen, oxygen and a number of other gases, aqueous ammonia solutions, aqueous solutions of ethyl alcohol, various metal alloys. The pure substances making up a mixture are called components or constituents.

Mixture of ideal gases

Basic assumption is that the gases in the mixture do not interact with each other.

Consider a mixture with components $l = 1, 2, 3, \dots$ with masses $m_1, m_2, m_3, \dots, m_i$ and with $N_1, N_2, N_3, \dots, N_i, \dots$ number of moles.

The total mixture occupies a volume V , has a total pressure P and temperature T (which is also the temperature of each of the component species)

The total mass

$$m = \sum m_i \quad (4.1)$$

Total number of mole N

$$N = \sum N_i \quad (4.2)$$

Mass fraction of species i

$$\phi_i = \frac{m_i}{m} \quad (4.3)$$

Mole fraction of species i

$$Y_i = \frac{N_i}{N} \quad (4.4)$$

The mass and number of moles of species i are related by

$$m_i = N_i M_i \quad (4.5)$$

N_i is the number of moles of species i and M_i is the molar mass of species i

Also to be noted

$$\sum \phi_i = 1 \quad \text{and} \quad \sum Y_i = 1 \quad (4.6)$$

We can also define a molar mass of the mixture as

$$M = \frac{m}{N} = \frac{\sum N_i M_i}{N} \quad (4.7)$$

or,

$$M = \sum \frac{N_i}{N} M_i$$

or,

$$M = \sum Y_i M_i$$

Dalton 's Law of partial pressure

Total pressure of an ideal gas mixture is equal to the sum of the partial pressures of the constituent components, That is

$$P = \sum P_i \quad (4.9)$$

P is the total pressure of the mixture

P_i is the partial pressure of species i

= pressure of the species if it existed alone in the given temperature T and volume V

$$P_i = \frac{N_i \hat{R} T}{V} \quad (4.10)$$

\hat{R} is the universal gas constant = 8.314 kJ/k mol K

Amagat's Law:

Volume of an ideal gas mixture is equal to the sum of the partial volumes

$$V = \sum V_i \quad (4.11)$$

V = total volume of the mixture

V_i = partial volume of the species i

= volume of the species if it existed alone in the given temperature T and pressure

For an ideal gas

$$V_i = \frac{N_i \hat{R}T}{P} \quad (4.12)$$

Amagat's Law

$$V = \sum V_i = \frac{\sum N_i \hat{R}T}{P} = \frac{\hat{R}T}{P} \sum N_i = \frac{\hat{R}T}{P} N$$

Or

$$V = \frac{N \hat{R}T}{P} \quad (4.13)$$

The volume fraction of species i

$$\frac{V_i}{V} = \frac{N_i \hat{R}T}{P} \frac{P}{N \hat{R}T} = \frac{N_i}{N} = Y_i$$

or,

$$\frac{V_i}{V} = Y_i \quad (34.16)$$

Volume fraction = Mole fraction

Mass based analysis is known as gravimetric analysis

Mole based analysis is known as molar analysis

Mole Fraction:

The composition of a gas mixture can be described by the mole fractions of the gases present. The mole fraction (X) of any component of a mixture is the ratio of the number of moles of that component to the total number of moles of all the species present in the mixture (n_{tot}):

$x_A = \text{moles of A} / \text{total moles}$

$= n_A / n_{\text{tot}}$

$= n_A / (n_A + n_B + \dots)$

The mole fraction is a dimensionless quantity between 0 and 1.

If $x_A=1.0$, then the sample is pure A, not a mixture.

If $x_A=0$, then no A is present in the mixture.

The sum of the mole fractions of all the components present must equal 1.

To see how mole fractions can help us understand the properties of gas mixtures, let's evaluate the ratio of the pressure of a gas A to the total pressure of a gas mixture that contains A. We can use the ideal gas law to describe the pressures of both gas A and the mixture: $P_A=n_A RT/V$ and $P_{tot}=n_{tot} RT/V$. The ratio of the two is thus

$$P_A/P_{tot}= n_A/n_{tot}=x_A$$

$$P_A=x_A P_{tot}$$

Mass Fraction:

the mass fraction of a substance within a mixture is the ratio of the mass of that substance to the total mass of the mixture.

Expressed as a formula, the mass fraction is

According to the conservation of mass, we have:

To change from a mass fraction analysis to a mole fraction analysis, we can show that

$$y_i = \frac{m_{f,i} / M_i}{\sum_{i=1}^t m_{f,i} / M_i}$$

Problem 12-30

P-v-T BEHAVIOR OF GAS MIXTURES

A rigid tank contains 8 kmol of O₂ and 10 kmol of CO₂ gases at 290 K and 150 kPa. Estimate the volume of the tank.

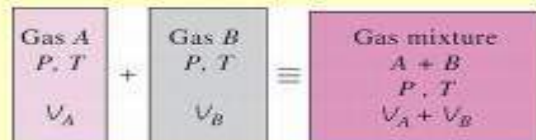

$$V_m = \sum_{i=1}^k V_i(T_m, P_m)$$

$$V_m = \frac{N_m R_u T_m}{P_m} = \frac{(18 \text{ kmol})(8.314 \text{ kPa} \cdot \text{m}^3/\text{kmol} \cdot \text{K})(290 \text{ K})}{150 \text{ kPa}} = 289.3 \text{ m}^3$$

Answer: 289 m³

Problem 12-32

P-v-T BEHAVIOR OF GAS MIXTURES

A rigid tank contains 0.5 kmol of Ar and 2 kmol of N₂ at 250 kPa and 280 K. The mixture is now heated to 400 K. Determine the volume of the tank and the final pressure of the mixture.

$$V_m = \frac{N_m R_u T_m}{P_m} = \frac{(2.5 \text{ kmol})(8.314 \text{ kPa} \cdot \text{m}^3/\text{kmol} \cdot \text{K})(280 \text{ K})}{250 \text{ kPa}} = 23.3 \text{ m}^3$$

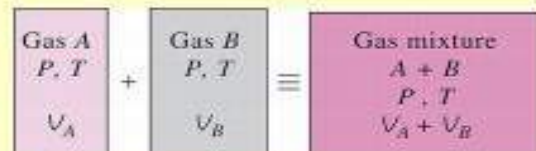

$$V_m = \sum_{i=1}^k V_i(T_m, P_m)$$

$$\frac{P_2 V_2}{T_2} = \frac{P_1 V_1}{T_1} \rightarrow P_2 = \frac{T_2}{T_1} P_1 = \frac{400 \text{ K}}{280 \text{ K}} (250 \text{ kPa}) = 357.1 \text{ kPa}$$

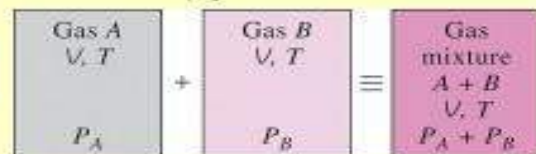

$$P_m = \sum_{i=1}^k P_i(T_m, V_m)$$

Example 0.3 m^3 of helium at 20 bar and 30°C is mixed with 0.7 m^3 of oxygen at 5 bar and 5°C by opening the valve between two tanks. Calculate the heat transfer, if the final temperature of the mixture is 25°C .

Solution.

Given: Volume of helium, $v_{\text{He}} = 0.3 \text{ m}^3$
 Pressure of helium, $p_{\text{He}} = 20 \text{ bar} = 20 \times 10^2 \text{ kN/m}^2$
 Temperature of helium, $T_{\text{He}} = 30^\circ\text{C} = 30 + 273 = 303 \text{ K}$
 Volume of oxygen, $v_{\text{O}_2} = 0.7 \text{ m}^3$
 Pressure of oxygen, $p_{\text{O}_2} = 5 \text{ bar} = 5 \times 10^2 \text{ kN/m}^2$
 Temperature of oxygen, $T_{\text{O}_2} = 5^\circ\text{C} = 5 + 273 = 278 \text{ K}$
 Temperature of the mixture,
 $T_{\text{mix}} = 25^\circ\text{C} = 25 + 273 = 298 \text{ K}$

First of all, let us find the mass and specific heat at constant volume for helium (He) and oxygen (O_2).

We know that gas constant for helium,

$$R_{\text{He}} = \frac{R_u}{\text{Molecular mass of helium } (M_{\text{He}})} = \frac{8.314}{4}$$

$$= 2.0785 \text{ kJ/kg K}$$

and gas constant for oxygen, $R_{\text{O}_2} = \frac{R_u}{M_{\text{O}_2}} = \frac{8.314}{32} = 0.26 \text{ kJ/kg K}$

From the characteristic equation of gas, $pV = mRT$, we have

$$\text{Mass of helium, } m_{\text{He}} = \frac{p_{\text{He}} \cdot v_{\text{He}}}{R_{\text{He}} T_{\text{He}}} = \frac{20 \times 10^2 \times 0.3}{2.0785 \times 303} = 0.9527 \text{ kg}$$

and mass of oxygen,

$$m_{O_2} = \frac{P_{O_2} v_{O_2}}{R_{O_2} T_{O_2}} = \frac{5 \times 10^4 \times 0.7}{0.26 \times 278} = 4.842$$

∴ Total mass of the mixture,

$$m = m_{He} + m_{O_2} = 0.9527 + 4.842 = 5.7947 \text{ kg}$$

Specific heat at constant volume for helium,

$$(c_v)_{He} = \frac{R_{He}}{\gamma_{He} - 1} = \frac{2.0785}{1.66 - 1} = 3.15 \text{ kJ/kg} \quad \dots(\because \gamma_{He} = 1.66)$$

Specific heat at constant volume for oxygen,

$$(c_v)_{O_2} = \frac{R_{O_2}}{\gamma_{O_2} - 1} = \frac{0.26}{1.4 - 1} = 0.65 \text{ kJ/kg K} \quad \dots(\because \gamma_{O_2} = 1.4)$$

and specific heat at constant volume for the gas mixture,

$$(c_v)_{mix} = \frac{m_{He} (c_v)_{He} + m_{O_2} (c_v)_{O_2}}{m} = \frac{0.9527 \times 3.15 + 4.842 \times 0.65}{5.7947} = 0.95$$

We know that initial internal energy before mixing,

$$\begin{aligned} U_1 &= m_{He} (c_v)_{He} T_{He} + m_{O_2} (c_v)_{O_2} T_{O_2} \\ &= 0.9527 \times 3.15 \times 303 + 4.842 \times 0.65 \times 278 \\ &= 909.3 + 874.95 = 1784.25 \text{ kJ} \end{aligned}$$

and final internal energy after mixing,

$$\begin{aligned} U_2 &= m (c_v)_{mix} T_{mix} \\ &= 5.7947 \times 1.061 \times 298 = 1832.15 \text{ kJ} \end{aligned}$$

∴ Heat transfer,

$$Q = U_2 - U_1 = 1832.15 - 1784.25 = 47.9 \text{ kJ Ans.}$$

Example . Find the increase in entropy when 2 kg of oxygen at 60°C are mixed with 6 kg of nitrogen at the same temperature. The initial pressure of each constituent is 103 kPa and is same as that of the mixture.

Solution.

Given: Mass of oxygen, $m_{O_2} = 2$ kg
 Temperature of oxygen, $T_{O_2} = 60^\circ\text{C} = 60 + 273 = 333$ K
 Mass of nitrogen, $m_{N_2} = 6$ kg
 Initial pressure of each constituent,

$$p_{O_2} = p_{N_2} = 103 \text{ kPa}$$

We know that number of moles of oxygen,

$$n_{O_2} = \frac{\text{Mass of oxygen } (m_{O_2})}{\text{Molecular mass of oxygen } (M_{O_2})} = \frac{2}{32} = 0.0625$$

and number of moles of nitrogen,

$$n_{N_2} = \frac{m_{N_2}}{M_{N_2}} = \frac{6}{28} = 0.2143$$

Total number of moles in the mixture,

$$n = n_{O_2} + n_{N_2} = 0.0625 + 0.2143 = 0.2768$$

We know that mole fraction of oxygen,

$$x_{O_2} = \frac{n_{O_2}}{n} = \frac{p_{O_2}}{p} = \frac{0.0625}{0.2768} = 0.2258$$

and mole fraction of nitrogen,

$$x_{N_2} = \frac{n_{N_2}}{n} = \frac{p_{N_2}}{p} = \frac{0.2143}{0.2768} = 0.7742$$

We know that increase in entropy,

$$\begin{aligned} ds &= -2.3 n_{O_2} R_u \log \left(\frac{p_{O_2}}{p} \right) - 2.3 n_{N_2} R_u \log \left(\frac{p_{N_2}}{p} \right) \\ &= -2.3 \times 0.0625 \times 8.314 \log (0.2258) - 2.3 \times 0.2143 \times 8.314 \log (0.7742) \\ &= 0.7724 + 0.4555 = 1.2279 \text{ kJ/kg Ans.} \end{aligned}$$

VOLUMETRIC ANALYSIS AND GRAVIMETRIC ANALYSIS

The mixture of gases may be analysed either on the volumetric basis or on mass basis (*i.e.* gravimetric basis). Such analysis are called *volumetric analysis* and *gravimetric analysis* respectively. In order to convert the volumetric analysis of a gas mixture into mass or gravimetric analysis, first of all multiply the volume of each constituent to its own molecular mass to obtain the mass of that constituent. Add up these masses to obtain the total mass of the mixture. Now divide the mass of each constituent to the total mass of the mixture which gives the mass fraction of each constituent. The procedure is best explained in the following example.

Example 11.9. A mixture of gases has the following volumetric composition:

$$CO_2 = 12\%; O_2 = 4\%; N_2 = 82\%; CO = 2\%$$

Calculate: 1. Gravimetric composition; 2. Molecular mass of the mixture; and 3. Gas constant for the mixture.

Solution.

Given: Volume of carbon dioxide (CO_2) in 1 m^3 of the mixture = $12\% = 0.12$

Volume of oxygen (O_2) = $4\% = 0.04$

Volume of nitrogen (N_2) = $82\% = 0.82$

Volume of carbon monoxide (CO) = $2\% = 0.02$

1. Gravimetric composition

We have already discussed in Art. 11.4 that the volume fraction (z) is equal to the mole fraction (x).

We also know that *mass of the constituent per mole of the mixture

$$= x \times M, \text{ where } M \text{ is the molecular mass of the constituent.}$$

Using these relations, the results may be tabulated as follows:

Constituent	% by volume or % by mole (a)	**kg mole per mole of mixture or mole fraction or volume fraction (x) (b)	Molecular mass (M) (c)	Mass of the constituent per mole of the mixture $m = x \times M$ (d)	% Mass $= \frac{(d)}{\Sigma(d)} \times 100$
CO_2	12	0.12	44	5.28	$\frac{5.28}{30.08} \times 100 = 17.55$
O_2	4	0.04	32	1.28	$\frac{1.28}{30.08} \times 100 = 4.26$
N_2	82	0.82	28	22.96	$\frac{22.96}{30.08} \times 100 = 76.33$
CO	2	0.02	28	0.56	$\frac{0.56}{30.08} \times 100 = 1.86$
Total	100	1.00		$\Sigma(d) = 30.08$	100

* We know that mole fraction of the constituent (say x_a)

$$= \frac{\text{Number of moles of the constituent (say } n_a)}{\text{Total number of moles in the mixture (} n)} \quad \dots [\text{For constituent } a]$$

and mass of the constituent = Number of moles of the constituent \times Molecular mass of the constituent

\therefore Mass of the constituent per mole of the mixture (i.e. when $n = 1$)

2. *Molecular mass of the mixture*

We know that molecular mass of the mixture

$$= \Sigma m = \Sigma(d) = 30.08 \text{ Ans.}$$

3. *Gas constant for the mixture*

$$R = \frac{R_u}{\Sigma m} = \frac{8.314}{30.08} = 0.2764 \text{ kJ/kg K Ans.}$$

Example 11.10. *A mixture of gases at a pressure of 4 bar has a temperature of 150°C. A sample is analysed and volumetric analysis is found to be*

$$CO_2 = 14\%; O_2 = 5\%; \text{ and } N_2 = 81\%$$

Determine the gravimetric analysis and partial pressure of the gases in the mixture. If 2.3 kg of mixture is cooled at constant pressure to 15°C; find the final volume.

Solution.

Given: Pressure of mixture of gases,

$$p = 4 \text{ bar} = 400 \text{ kN/m}^2$$

Temperature of mixture, $T = 150^\circ\text{C}$

Volume of carbon dioxide (CO_2) = 14% = 0.14

Volume of oxygen (O_2) = 5% = 0.05

Volume of nitrogen (N_2) = 81% = 0.81

Gravimetric analysis

As discussed in the previous example, the results of the gravimetric analysis are given in following table.

Constituent	% by volume or % by mole (a)	Volume fraction or mole fraction (x) (b)	Molecular mass (M) (c)	Mass of the constituent per mole of the mixture $m = x \times M$ (d)	% Mass $\frac{(d)}{\Sigma(d)} \times 100$
CO ₂	14	0.14	44	6.16	$\frac{6.16}{30.44} \times 100 = 20.2$
O ₂	5	0.05	32	1.6	$\frac{1.6}{30.44} \times 100 = 5.3$
N ₂	81	0.81	28	22.68	$\frac{22.68}{30.44} \times 100 = 74.5$
Total	100	1.00		$\Sigma(d) = 30.44$	100

Partial pressure of the gases in the mixture

We know that volume fraction is equal to the mole fraction.

∴ Partial pressure of carbon dioxide,

$$p_{\text{CO}_2} = x_{\text{CO}_2} \times p = 0.14 \times 4 = 0.56 \text{ bar Ans.}$$

Partial pressure of oxygen,

$$p_{\text{O}_2} = x_{\text{O}_2} \times p = 0.05 \times 4 = 0.20 \text{ bar Ans.}$$

and partial pressure of nitrogen,

$$p_{\text{N}_2} = x_{\text{N}_2} \times p = 0.81 \times 4 = 3.24 \text{ bar Ans.}$$

Final volume

Given: Mass of the mixture,

$$m_{\text{mix}} = 2.3 \text{ kg}$$

Temperature,

$$T = 15^\circ\text{C} = 15 + 273 = 288 \text{ K}$$

We know that number of moles in the mixture,

$$n = \frac{\text{Mass of the mixture } (m_{\text{mix}})}{\text{Total mass of the constituents per mole of the mixture } (\Sigma d)}$$

$$= \frac{2.3}{30.44} = 0.0756$$

Using the gas equation, we have

$$pv = n R_u T$$

$$\therefore v = \frac{n R_u T}{p} = \frac{0.0756 \times 8.314 \times 288}{400} = 0.453 \text{ m}^3 \text{ Ans.}$$

Atmospheric Air:

Atmospheric air makes up the environment in almost every type of air conditioning system. Hence a thorough understanding of the properties of atmospheric air and the ability to analyze various processes involving air is fundamental to air conditioning design.

Psychrometry is the study of the properties of mixtures of air and water vapour.

Atmospheric air is a mixture of many gases plus water vapour and a number of pollutants. The amount of water vapour and pollutants vary from place to place. The concentration of water vapour and pollutants decrease with altitude, and above an altitude of about 10 km, atmospheric air consists of only dry air. The pollutants have to be filtered out before processing the air. Hence, what we process is essentially a mixture of various gases that constitute air and water vapour. This mixture is known as moist air.

Psychrometric Properties:

Dry bulb temperature (DBT) is the temperature of the moist air as measured by a standard thermometer or other temperature measuring instruments.

Saturated vapour pressure (psat) is the saturated partial pressure of water vapour at the dry bulb temperature. This is readily available in thermodynamic tables and charts.

ASHRAE suggests the following regression equation for saturated vapour pressure of water, which is valid for 0 to 100°C.

Relative humidity (Φ) is defined as the ratio of the mole fraction of water vapour in moist air to mole fraction of water vapour in saturated air at the same temperature and pressure. Using perfect gas equation we can show that:

$$\phi = \frac{\text{partial pressure of water vapour}}{\text{saturation pressure of pure water vapour at same temperature}} = \frac{p_v}{p_{\text{sat}}}$$

Relative humidity is normally expressed as a percentage. When ϕ is 100 percent, the air is saturated.

Humidity ratio (W): The humidity ratio (or specific humidity) W is the mass of water associated with each kilogram of dry air¹. Assuming both water vapour and dry air to be perfect gases², the humidity ratio is given by:

$$W = \frac{\text{kg of water vapour}}{\text{kg of dry air}} = \frac{p_v V / R_v T}{p_a V / R_a T} = \frac{p_v / R_v}{(p_t - p_v) / R_a}$$

Substituting the values of gas constants of water vapour and air R_v and R_a in the above equation; the humidity ratio is given by:

$$W = 0.622 \frac{p_v}{p_t - p_v}$$

For a given barometric pressure p_t , given the DBT, we can find the saturated vapour pressure p_{sat} from the thermodynamic property tables on steam. Then using the above equation, we can find the humidity ratio at saturated conditions, W_{sat} .

It is to be noted that, W is a function of both total barometric pressure and vapor pressure of water.

Dew-point temperature: If unsaturated moist air is cooled at constant pressure, then the temperature at which the moisture in the air begins to condense is known as dew-point temperature (DPT) of air. An approximate equation for dew-point temperature is given by:

$$\text{DPT} = \frac{4030(\text{DBT} + 235)}{4030 - (\text{DBT} + 235)\ln\phi} - 235$$

where ϕ is the relative humidity (in fraction). DBT & DPT are in °C. Of course, since from its definition, the dew point temperature is the saturation temperature corresponding to the vapour pressure of water vapour, it can be obtained from steam tables

Degree of saturation μ : The degree of saturation is the ratio of the humidity ratio W to the humidity ratio of a saturated mixture W_s at the same temperature and pressure, i.e.,

$$\mu = \frac{W}{W_s} \Big|_{t,p}$$

Enthalpy: The enthalpy of moist air is the sum of the enthalpy of the dry air and the enthalpy of the water vapour. Enthalpy values are always based on some reference value. For moist air, the enthalpy of dry air is given a zero value at 0°C , and for water vapour the enthalpy of saturated water is taken as zero at 0°C .

The enthalpy of moist air is given by:

$$h = h_a + Wh_g = c_p t + W(h_{fg} + c_{pw} t)$$

where c_p = specific heat of dry air at constant pressure, kJ/kg.K
 c_{pw} = specific heat of water vapor, kJ/kg.K
 t = Dry-bulb temperature of air-vapor mixture, $^\circ\text{C}$
 W = Humidity ratio, kg of water vapor/kg of dry air
 h_a = enthalpy of dry air at temperature t , kJ/kg
 h_g = enthalpy of water vapor³ at temperature t , kJ/kg
 h_{fg} = latent heat of vaporization at 0°C , kJ/kg

The unit of h is kJ/kg of dry air. Substituting the approximate values of c_p and h_g , we obtain:

$$h = 1.005 t + W(2501 + 1.88t)$$

Humid specific heat: From the equation for enthalpy of moist air, the humid specific heat of moist air can be written as:

$$c_{pm} = c_p + W.c_{pw}$$

where c_{pm} = humid specific heat, kJ/kg.K
 c_p = specific heat of dry air, kJ/kg.K
 c_{pw} = specific heat of water vapor, kJ/kg
 W = humidity ratio, kg of water vapor/kg of dry air

Since the second term in the above equation ($w.c_{pw}$) is very small compared to the first term, for all practical purposes, the humid specific heat of moist air, c_{pm} can be taken as 1.0216 kJ/kg dry air.K

Specific volume: The specific volume is defined as the number of cubic meters of moist air per kilogram of dry air. From perfect gas equation since the volumes occupied by the individual substances are the same, the specific volume is also equal to the number of cubic meters of dry air per kilogram of dry air, i.e.,

$$v = \frac{R_a T}{p_a} = \frac{R_a T}{p_t - p_v} \quad \text{m}^3 / \text{kg dry air}$$

Psychrometric chart

A *Psychrometric chart* graphically represents the thermodynamic properties of moist air. Standard psychrometric charts are bounded by the dry-bulb temperature line (abscissa) and the vapour pressure or humidity ratio (ordinate). The Left Hand Side of the psychrometric chart is bounded by the saturation line. Figure 27.2 shows the schematic of a psychrometric chart. Psychrometric charts are readily available for standard barometric pressure of 101.325 kPa at sea level and for normal temperatures (0-50°C). ASHRAE has also developed psychrometric charts for other temperatures and barometric pressures (for low temperatures: -40 to 10°C, high temperatures 10 to 120°C and very high temperatures 100 to 120°C)

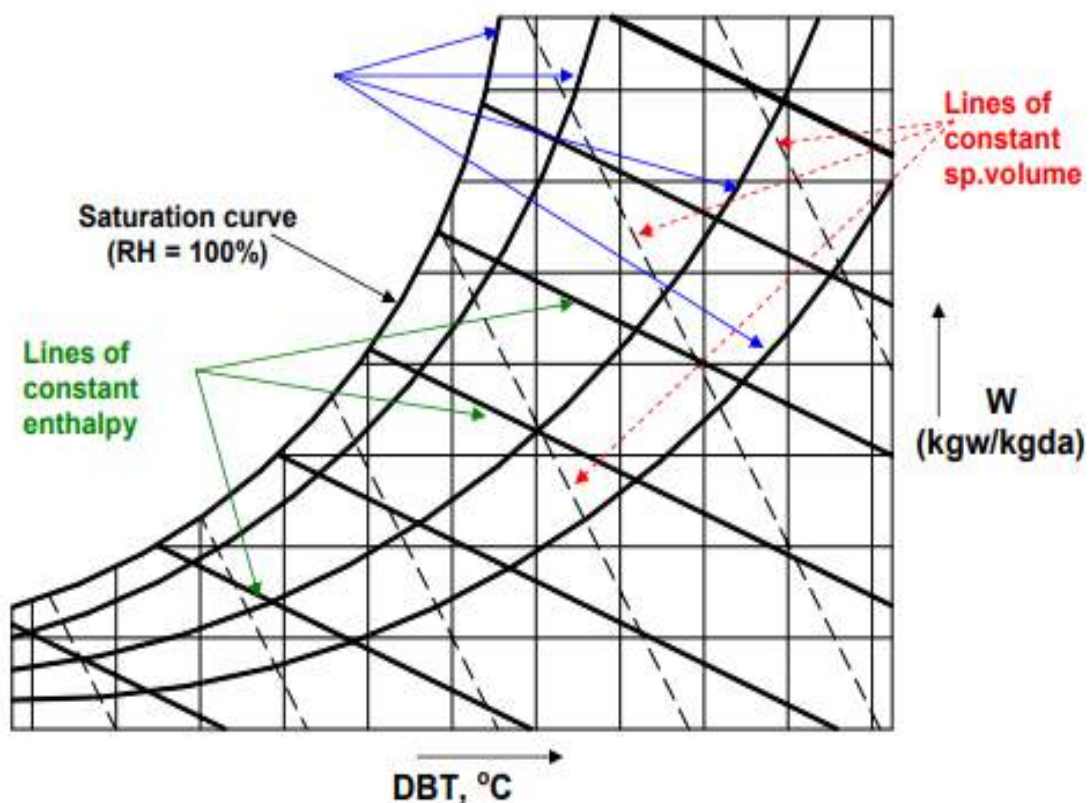

Schematic of a psychrometric chart for a given barometric pressure

Measurement of psychrometric properties:

Based on Gibbs' phase rule, the thermodynamic state of moist air is uniquely fixed if the barometric pressure and two other independent properties are known. This means that at a given barometric pressure, the state of moist air can be determined by measuring any two independent properties. One of them could be the dry-bulb temperature (DBT), as the measurement of this temperature is fairly simple and accurate. The accurate measurement of other independent parameters such as humidity ratio is very difficult in practice. Since measurement of temperatures is

easier, it would be convenient if the other independent parameter is also a temperature. Of course, this could be the dew-point temperature (DPT), but it is observed that accurate measurement of dew-point temperature is difficult. In this context, a new independent temperature parameter called the *wet-bulb temperature* (WBT) is defined. Compared to DPT, it is easier to measure the wet-bulb temperature of moist air. Thus knowing the dry-bulb and wet-bulb temperatures from measurements, it is possible to find the other properties of moist air.

To understand the concept of wet-bulb temperature, it is essential to understand the process of combined heat and mass transfer.

Combined heat and mass transfer; the straight line law

The straight line law states that "when air is transferring heat and mass (water) to or from a wetted surface, the condition of air shown on a psychrometric chart drives towards the saturation line at the temperature of the wetted surface".

For example, as shown in Fig.27.3, when warm air passes over a wetted surface its temperature drops from 1 to 2. Also, since the vapor pressure of air at 1 is greater than the saturated vapor pressure at t_w , there will be moisture transfer from air to water, i.e., the warm air in contact with cold wetted surface cools and dehumidifies. According to the straight line law, the final condition of air (i.e., 2) lies on a straight line joining 1 with t_w on the saturation line. This is due to the value of unity of the Lewis number, that was discussed in an earlier chapter on analogy between heat and mass transfer.

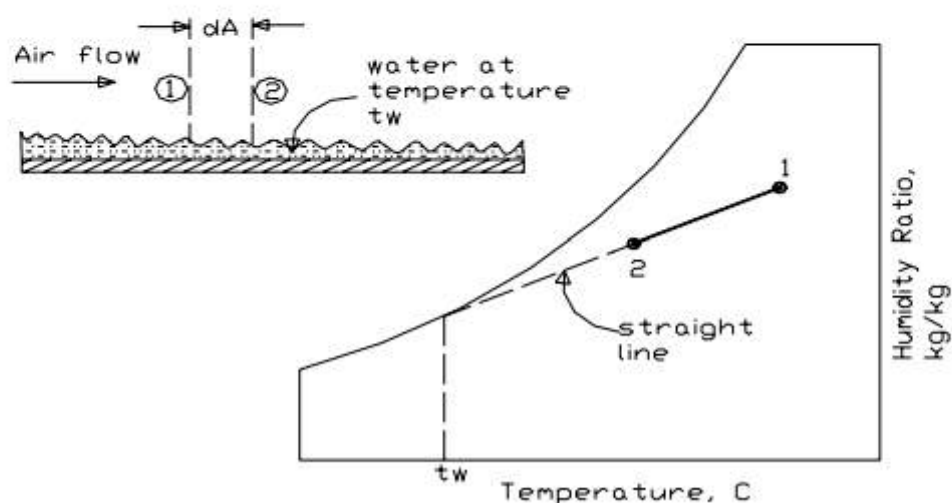

Fig.27.3: Principle of straight-line law for air-water mixtures

Adiabatic saturation and thermodynamic wet bulb temperature:

Adiabatic saturation temperature is defined as that temperature at which water, by evaporating into air, can bring the air to saturation at the same temperature adiabatically. An adiabatic saturator is a device using which one can measure theoretically the adiabatic saturation temperature of air.

As shown in Fig.27.4, an adiabatic saturator is a device in which air flows through an infinitely long duct containing water. As the air comes in contact with

water in the duct, there will be heat and mass transfer between water and air. If the duct is infinitely long, then at the exit, there would exist perfect equilibrium between air and water at steady state. Air at the exit would be fully saturated and its temperature is equal to that of water temperature. The device is adiabatic as the walls of the chamber are thermally insulated. In order to continue the process, make-up water has to be provided to compensate for the amount of water evaporated into the air. The temperature of the make-up water is controlled so that it is the same as that in the duct.

After the adiabatic saturator has achieved a steady-state condition, the temperature indicated by the thermometer immersed in the water is the thermodynamic wet-bulb temperature. The thermodynamic wet bulb temperature will be less than the entering air DBT but greater than the dew point temperature.

Certain combinations of air conditions will result in a given sump temperature, and this can be defined by writing the energy balance equation for the adiabatic saturator. Based on a unit mass flow rate of dry air, this is given by:

$$h_1 = h_2 - (W_2 - W_1)h_f$$

where h_f is the enthalpy of saturated liquid at the sump or thermodynamic wet-bulb temperature, h_1 and h_2 are the enthalpies of air at the inlet and exit of the adiabatic saturator, and W_1 and W_2 are the humidity ratio of air at the inlet and exit of the adiabatic saturator, respectively.

It is to be observed that the thermodynamic wet-bulb temperature is a thermodynamic property, and is independent of the path taken by air. Assuming the humid specific heat to be constant, from the enthalpy balance, the thermodynamic wet-bulb temperature can be written as:

$$t_2 = t_1 - \frac{h_{fg,2}}{c_{pm}} (w_2 - w_1)$$

where $h_{fg,2}$ is the latent heat of vaporization at the saturated condition 2. Thus measuring the dry bulb (t_1) and wet bulb temperature (t_2) one can find the inlet humidity ratio (W_1) from the above expression as the outlet saturated humidity ratio (W_2) and latent heat of vaporizations are functions of t_2 alone (at fixed barometric pressure).

On the psychrometric chart as shown in Fig.27.4, point 1 lies below the line of constant enthalpy that passes through the saturation point 2. $t_2 = f(t_1, W_1)$ is not a unique function, in the sense that there can be several combinations of t_1 and W_1 which can result in the same sump temperature in the adiabatic saturator. A line passing through all these points is a constant wet bulb temperature line. Thus all inlet conditions that result in the same sump temperature, for example point 1' have the same wet bulb temperature. The line is a straight line according to the straight-line law. The straight-line joining 1 and 2 represents the path of the air as it passes through the adiabatic saturator.

Normally lines of constant wet bulb temperature are shown on the psychrometric chart. The difference between actual enthalpy and the enthalpy obtained by following constant wet-bulb temperature is equal to $(w_2-w_1)h_f$.

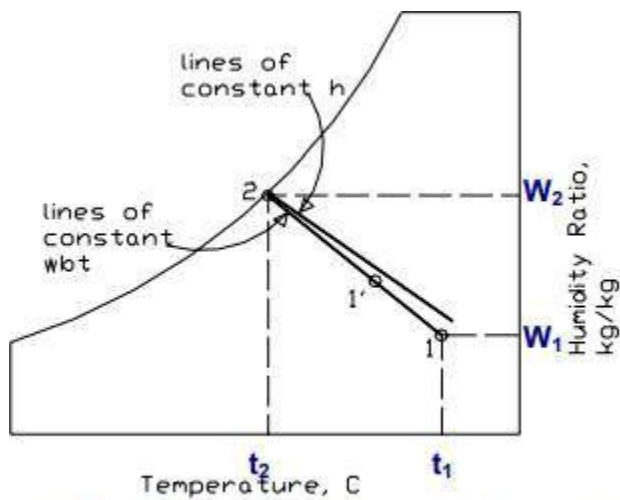
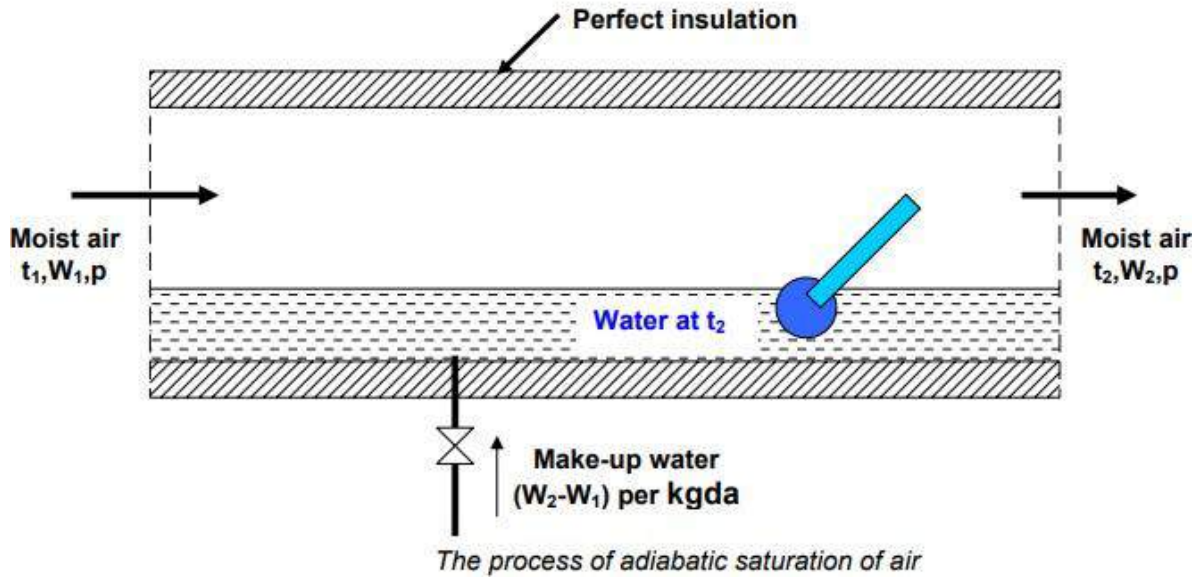

Adiabatic saturation process 1-2 on psychrometric chart

Wet-Bulb Thermometer:

In practice, it is not convenient to measure the wet-bulb temperature using an adiabatic saturator. In stead, a thermometer with a wetted wick is used to measure the wet bulb temperature as shown in Fig.27.6. It can be observed that since the area of the wet bulb is finite, the state of air at the exit of the wet bulb will not be saturated, in stead it will be point 2 on the straight line joining 1 and i , provided the temperature of water on the wet bulb is i . It has been shown by Carrier, that this is a valid assumption for air-water mixtures. Hence for air-water mixtures, one can assume that the temperature measured by the wet-bulb thermometer is equal to the thermodynamic wet-bulb temperature⁴. For other gas-vapor mixtures, there can be appreciable difference between the thermodynamic and actual wet-bulb temperatures.

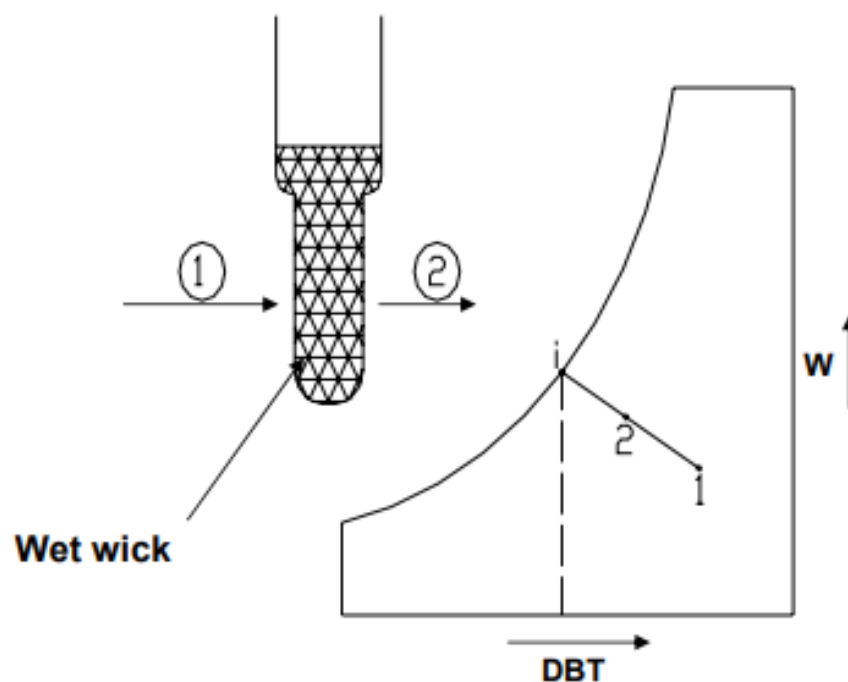

Schematic of a wet-bulb thermometer and the process on psychrometric chart

Calculation of psychrometric properties from p, DBT and WBT:

As mentioned before, to fix the thermodynamic state of moist air, we need to know three independent properties. The properties that are relatively easier to measure, are: the barometric pressure, dry-bulb temperature and wet-bulb temperature. For a given barometric pressure, knowing the dry bulb and wet bulb temperatures, all other properties can be easily calculated from the psychrometric equations. The following are the empirical relations for the vapor pressure of water in moist air:

i) Modified Apjohn equation:

$$p_v = p'_v - \frac{1.8p(t - t')}{2700} \quad (27.15)$$

ii) Modified Ferrel equation:

$$p_v = p'_v - 0.00066p(t - t') \left[1 + \frac{1.8t}{1571} \right] \quad (27.16)$$

iii) Carrier equation:

$$p_v = p'_v - \frac{1.8(p - p'_v)(t - t')}{2800 - 1.3(1.8t + 32)} \quad (27.17)$$

where t = dry bulb temperature, °C
 t' = wet bulb temperature, °C
 p = barometric pressure
 p_v = vapor pressure
 p'_v = saturation vapor pressure at wet-bulb temperature

The units of all the pressures in the above equations should be consistent.

Once the vapor pressure is calculated, then all other properties such as relative humidity, humidity ratio, enthalpy, humid volume etc. can be calculated from the psychrometric equations presented earlier.

Psychrometer:

Any instrument capable of measuring the psychrometric state of air is called a psychrometer. As mentioned before, in order to measure the psychrometric state of air, it is required to measure three independent parameters. Generally two of these are the barometric pressure and air dry-bulb temperature as they can be measured easily and with good accuracy.

Two types of psychrometers are commonly used. Each comprises of two thermometers with the bulb of one covered by a moist wick. The two sensing bulbs are separated and shaded from each other so that the radiation heat transfer between them becomes negligible. Radiation shields may have to be used over the bulbs if the surrounding temperatures are considerably different from the air temperature.

The *sling psychrometer* is widely used for measurements involving room air or other applications where the air velocity inside the room is small. The sling psychrometer consists of two thermometers mounted side by side and fitted in a frame with a handle for whirling the device through air. The required air circulation (≈ 3 to 5 m/s) over the sensing bulbs is obtained by whirling the psychrometer (≈ 300 RPM). Readings are taken when both the thermometers show steady-state readings.

In the *aspirated psychrometer*, the thermometers remain stationary, and a small fan, blower or syringe moves the air across the thermometer bulbs.

The function of the wick on the wet-bulb thermometer is to provide a thin film of water on the sensing bulb. To prevent errors, there should be a continuous film of water on the wick. The wicks made of cotton or cloth should be replaced frequently, and only distilled water should be used for wetting it. The wick should extend beyond the bulb by 1 or 2 cms to minimize the heat conduction effects along the stem.

Other types of psychrometric instruments:

1. Dunmore Electric Hygrometer
2. DPT meter
3. Hygrometer (Using horse's or human hair)

5. On a particular day the weather forecast states that the dry bulb temperature is 37°C , while the relative humidity is 50% and the barometric pressure is 101.325 kPa. Find the humidity ratio, dew point temperature and enthalpy of moist air on this day.

Ans.:

At 37°C the saturation pressure (p_s) of water vapour is obtained from steam tables as **6.2795 kPa**.

Since the relative humidity is 50%, the vapour pressure of water in air (p_v) is:

$$p_v = 0.5 \times p_s = 0.5 \times 6.2795 = 3.13975 \text{ kPa}$$

the humidity ratio W is given by:

$$W = 0.622 \times p_v / (p_t - p_v) = 0.622 \times 3.13975 / (101.325 - 3.13975) = 0.01989 \text{ kgw/kgda}$$

(Ans.)

The enthalpy of air (h) is given by the equation:

$$h = 1.005t + W(2501 + 1.88t) = 1.005 \times 37 + 0.01989(2501 + 1.88 \times 37) = 88.31 \text{ kJ/kgda}$$

(Ans.)

7. Moist air at 1 atm. pressure has a dry bulb temperature of 32°C and a wet bulb temperature of 26°C. Calculate a) the partial pressure of water vapour, b) humidity ratio, c) relative humidity, d) dew point temperature, e) density of dry air in the mixture, f) density of water vapour in the mixture and g) enthalpy of moist air using perfect gas law model and psychrometric equations.

Ans.:

a) Using modified Apjohn equation and the values of DBT, WBT and barometric pressure, the vapour pressure is found to be:

$$p_v = 2.956 \text{ kPa} \quad (\text{Ans.})$$

b) The humidity ratio W is given by:

$$W = 0.622 \times 2.956 / (101.325 - 2.956) = 0.0187 \text{ kgw/kgda} \quad (\text{Ans.})$$

c) Relative humidity RH is given by:

$$RH = (p_v/p_s) \times 100 = (p_v/\text{saturation pressure at } 32^\circ\text{C}) \times 100$$

From steam tables, the saturation pressure of water at 32°C is 4.7552 kPa, hence,

$$RH = (2.956/4.7552) \times 100 = 62.16\% \quad (\text{Ans.})$$

d) Dew point temperature is the saturation temperature of steam at 2.956 kPa. Hence using steam tables we find that:

$$DPT = T_{\text{sat}}(2.956 \text{ kPa}) = 23.8^\circ\text{C} \quad (\text{Ans.})$$

e) Density of dry air and water vapour

Applying perfect gas law to dry air:

$$\begin{aligned} \text{Density of dry air } \rho_a &= (p_a/R_a T) = (p_t - p_v) / R_a T = (101.325 - 2.956) / (287.035 \times 305) \times 10^3 \\ &= 1.1236 \text{ kg/m}^3 \text{ of dry air} \quad (\text{Ans.}) \end{aligned}$$

f) Similarly the density of water vapour in air is obtained using perfect gas law as:

$$\text{Density of water vapour } \rho_v = (p_v/R_v T) = 2.956 \times 10^3 / (461.52 \times 305) = 0.021 \text{ kg/m}^3 \quad (\text{Ans.})$$

g) Enthalpy of moist air is found from the equation:

$$\begin{aligned} h &= 1.005 \times t + W(2501 + 1.88 \times t) = 1.005 \times 32 + 0.0187(2501 + 1.88 \times 32) \\ h &= 80.05 \text{ kJ/kg of dry air} \quad (\text{Ans.}) \end{aligned}$$

Industry applications

- Automobile industries.
- Refrigeration industries
- Air craft applications
- Defense industries
- Thermal power plants etc.

Assignment Questions

1. Define mole fraction, and mass fraction. Explain about volumetric and gravimetric analysis?
2. Explain adiabatic saturation temperature?
3. Explain psychrometric charts while representing all the properties?
4. Locate i) sensible heating ii) sensible cooling iii) heating and humidification iv) heating and dehumidification on psychrometric chart?
5. Compare degree of saturation and adiabatic saturation.
6. a) Define saturated air, wet bulb temperature, specific humidity and relative humidity. b) State and explain i) Dalton's law of partial pressure ii) Avagadro's law iii) Amagat's law of additive volumes.
7. The analysis by weight of a perfect gas mixture at 200C and 1.3bar is 10%O₂, 70%N₂,15%CO₂ and 5%CO. For a reference state of 00C and 1bar, determine partial pressure of the constituent and gas constant of mixture.

Tutorial Questions

1. 1.8 kg of oxygen at 48°C is mixed with 6.2 kg of nitrogen at the same temperature. Both oxygen and nitrogen are at the pressure of 102 k Pa before and after mixing. Find the increase in entropy.
2. A mixture of ideal air and water vapour at a dbt of 220°C and a total pressure of 730 mm Hg abs. has a temperature of adiabatic saturation of 150°C . Calculate: i. the specific humidity in gms per kg of dry air. ii. the partial pressure of water vapour the relative humidity, and iv. enthalpy of the mixture per kg of dry air.
3. Atmospheric air at 1.0132 bar has a DBT of 30°C and WBT of 24°C . Compute, (i) The partial pressure of water vapour (ii) Specific humidity (iii) The dew point temperature (iv) Relative humidity (v) Degree of saturation (vi) Density of air in the mixture (vii) Density of the vapour in the mixture (viii) The enthalpy of the mixture.
4. A mixture of ideal gases consists of 3 kg of nitrogen and 6 kg of CO_2 at a pressure of 250 kpa and a temperature of 230°C . Find (a) the mole fraction of each constituent (b) equivalent weight of the mixture (c) equivalent gas constant of the mixture (d) partial pressures and partial volumes (e) volume and density of mixture C_p and C_v of mixture. If the mixture is heated at constant volume to 60°C and the internal energy, enthalpy, and entropy of mixture. Find the changes in internal energy, enthalpy, and entropy of mixture if the heating is done at constant pressure. Take γ for CO_2 and N_2 be 1.286 and 1.4.
5. Consider a mixture of ideal gases comprising 2kg of nitrogen and 3kg of carbon dioxide 250kPa pressure and 300K temperature . Make calculations for i) Mole fraction, partial pressure and partial volume of each constituent. ii) Molecular mass, gas constant, volume and density of the mixture iii) Specific heats and adiabatic exponent for the mixture Take $\gamma = 1.286$ for CO_2 and $\gamma = 1.4$ for nitrogen.

UNIT-V

Gas Power Cycles

Introduction

For the purpose of thermodynamic analysis of the internal combustion engines, the following approximations are made:

- The engine is assumed to operate on a closed cycle with a fixed mass of air which does not undergo any chemical change.
- The combustion process is replaced by an equivalent energy addition process from an external source.
- The exhaust process is replaced by an equivalent energy rejection process to external surroundings by means of which the working fluid is restored to the initial state.
- The air is assumed to behave like an ideal gas with constant specific heat. These cycles are usually referred to as air standard cycle.

Otto Cycle

The Air Standard Otto cycle is named after its inventor **Nikolaus A. Otto** . Figures 5.1 (a), (b) and (c) illustrate the working principles of an Otto cycle. The Otto cycle consists of the following processes.

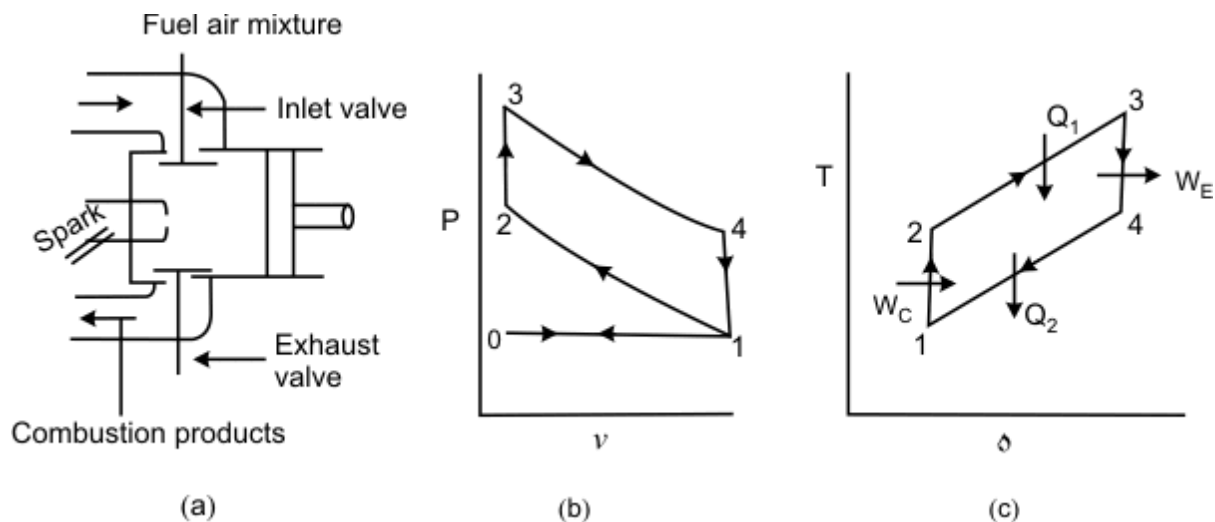

Figure 5.1

0-1: Constant pressure suction during which a mixture of fuel vapour and air is drawn into the cylinder as the piston executes an outward stroke.

1-2: The mixture is compressed isentropically due to the inward motion of the piston. Because of the **isentropic compression** , the temperature of the gas increases.

2-3: The hot fuel vapour-air mixture is ignited by means of an electric spark. Since the combustion is instantaneous, there is not enough time for the piston to move outward. This process is approximated as a **constant volume energy addition process**.

3-4: The hot combustion products undergo **isentropic expansion** and the piston executes an outward motion.

4-1: The exhaust port opens and the combustion products are exhausted into the atmosphere. The process is conveniently approximated as a **constant-volume energy rejection process**.

1-0: The remaining combustion products are exhausted by an inward motion of the piston at constant pressure.

Effectively there are four strokes in the cycle. These are suction, compression, expansion, and exhaust strokes, respectively. From the P-V diagram it can be observed that the work done during the process 0-1 is exactly balanced by the work done during 1-0. Hence for the purpose of thermodynamic analysis we need to consider only the cycle 1-2-3-4, which is air-standard Otto Cycle.

$$\eta = \frac{W_{\text{net}}}{Q_1} = \frac{(Q_1 - Q_2)}{Q_1} \quad (5.1)$$

Where Q_1 and Q_2 denote the energy absorbed and energy rejected in the form of heat. Application of the first law of thermodynamics to process 2-3 and 4-1 gives:

$$Q_1 = U_3 - U_2 = m(u_3 - u_2) = mc_v(T_3 - T_2) \quad (5.2)$$

$$Q_2 = U_4 - U_1 = m(u_4 - u_1) = mc_v(T_4 - T_1) \quad (5.3)$$

Therefore,

$$\eta = 1 - \frac{T_4 - T_1}{T_3 - T_2} \quad (5.4)$$

1-2 and 3-4 are isentropic processes for which $TV^{r-1} = \text{constant}$

Therefore,

$$\frac{T_1}{T_2} = \left(\frac{V_2}{V_1}\right)^{r-1} \quad \text{or} \quad \frac{T_2}{T_1} = \left(\frac{V_1}{V_2}\right)^{r-1} \quad (5.5)$$

and

$$\frac{T_3}{T_4} = \left(\frac{V_4}{V_3} \right)^{\gamma-1} \quad (5.6)$$

But

$$V_1 = V_4 \quad \text{and} \quad V_2 = V_3 \quad (5.7)$$

Hence

$$\frac{T_3}{T_4} = \left(\frac{V_1}{V_2} \right)^{\gamma-1} \quad (5.8)$$

So,

$$\frac{T_2}{T_1} = \frac{T_3}{T_4} \quad \text{or} \quad \frac{T_3}{T_2} = \frac{T_4}{T_1} \quad (5.9)$$

$$\frac{T_3}{T_2} - 1 = \frac{T_4}{T_1} - 1 \quad (5.10)$$

or

$$\frac{T_3 - T_2}{T_2} = \frac{T_4 - T_1}{T_1} \quad \text{or} \quad \frac{T_4 - T_1}{T_3 - T_2} = \frac{T_1}{T_2} \quad (5.11)$$

and

$$\frac{T_1}{T_2} = \left(\frac{V_2}{V_1} \right)^{\gamma-1} = \left(\frac{1}{r_0} \right)^{\gamma-1} \quad (5.12)$$

$$\eta = 1 - \left(\frac{1}{r_0} \right)^{\gamma-1} \quad (5.13)$$

Where

$$r_0 = \frac{V_1}{V_2} = \text{Compression ratio} \quad (5.14)$$

Since $\gamma > 1$, the efficiency of the Otto cycle increases with increasing compression ratio. However, in an actual engine, the compression ratio can not be increased indefinitely since higher compression ratios give higher values of T_2 and this leads to **spontaneous** and **uncontrolled** combustion of the gasoline-air mixture in the cylinder. Such a condition is usually called knocking.

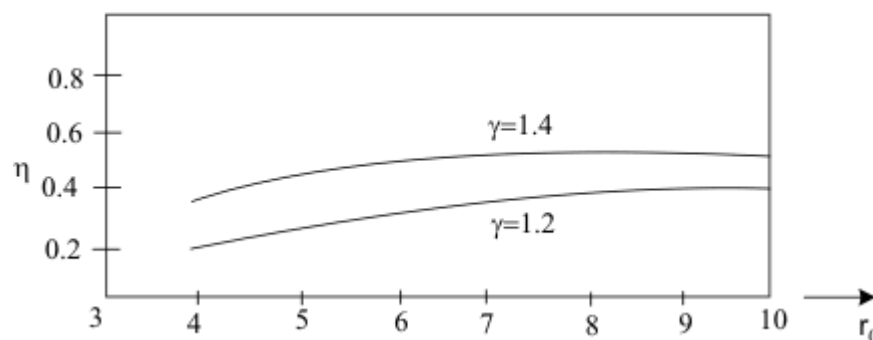

Figure 5.2

Performance of an engine is evaluated in terms of the efficiency (see Figure 5.2). However, sometime it is convenient to describe the performance in terms of mean effective pressure, an imaginary pressure obtained by equating the cycle work to the work evaluated by the following relation

$$W_{\text{net}} = P_{\text{me}} \int dV = P_{\text{me}} (V_1 - V_2) \quad (5.15)$$

The mean effective pressure is defined as the net work divided by the displacement volume.

That is

$$P_m = \frac{W_{net}}{(V_1 - V_2)}$$

DIESEL CYCLE

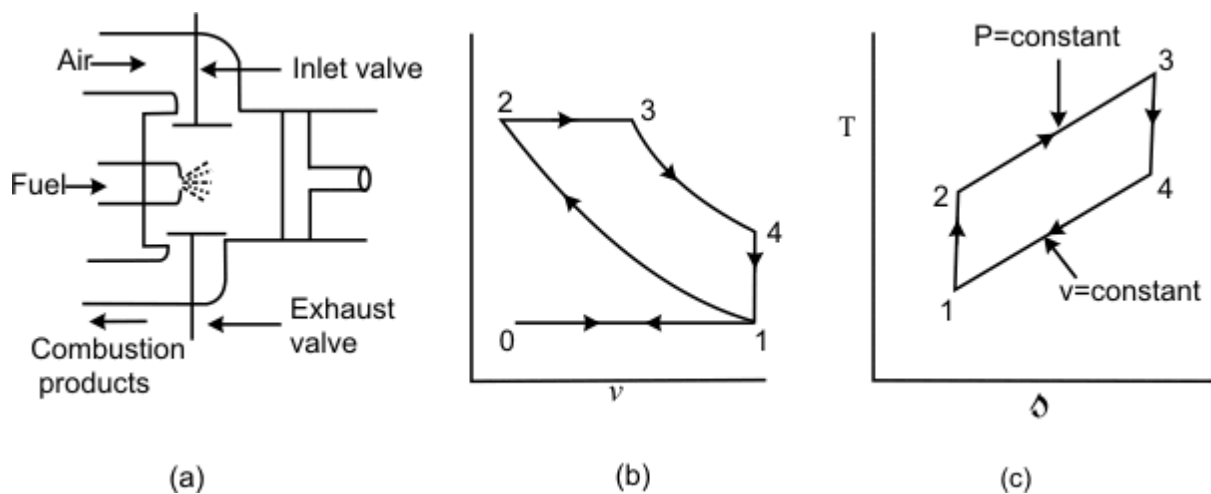

Figure 5.3 (a), (b) and (c)

The Diesel cycle was developed by Rudolf Diesel in Germany. Figures 5.3 (a), (b) and (c) explain the working principle of an Air Standard Diesel cycle. The following are the processes.

0-1: Constant pressure suction during which fresh air is drawn into the cylinder as the piston executes the outward motion.

1-2: The air is compressed isentropically. Usually the compression ratio in the **Diesel cycle is much higher than that of Otto cycle**. Because of the high compression ratio, the temperature of the gas at the end of isentropic compression is so high that when fuel is injected, it gets ignited immediately.

2-3: The fuel is injected into the hot compressed air at state 2 and the fuel undergoes a chemical reaction. The combustion of Diesel oil in air is not as spontaneous as the combustion of gasoline and the combustion is relatively slow. Hence the piston starts moving outward as combustion takes place. The combustion process is conveniently approximated as a **constant pressure energy addition process**.

3-4: The combustion products undergo isentropic expansion and the piston executes an outward motion.

4-1: The combustion products are exhausted at constant volume when the discharge port opens. This is replaced by a **constant-volume energy rejection process**.

1-0: The remaining combustion products are exhausted at constant pressure by the inward motion of the piston.

In the analysis of a Diesel cycle, two important parameters are: compression

ratio ($r_0 = V_1/V_2$) and the cut-off ratio (r_c). The cut-off ratio is defined as the ratio of the volume at the end of constant-pressure energy addition process to the volume at the beginning of the energy addition process.

$$r_c = \frac{V_3}{V_2} \quad (5.16)$$

$$\text{Energy added} = Q_1 = mc_p (T_3 - T_2) \quad (5.17)$$

$$\text{Energy rejected} = Q_2 = mc_v (T_4 - T_1) \quad (5.18)$$

$$\eta = \frac{Q_1 - Q_2}{Q_1} = 1 - \frac{T_4 - T_1}{\gamma(T_3 - T_2)} \quad (5.19)$$

or

$$\eta = 1 - \frac{\{(T_4/T_1) - 1\} T_1}{\{(T_3/T_2) - 1\} \gamma T_2} \quad (5.20)$$

1-2 is Isentropic:

$$\frac{T_1}{T_2} = \left(\frac{V_2}{V_1}\right)^{\gamma-1} = \left(\frac{1}{r_0}\right)^{\gamma-1}$$

4-1 is Constant volume:

$$\frac{T_4}{T_1} = \frac{P_4}{P_1} = \frac{P_4}{P_3} \times \frac{P_3}{P_1}$$

But $P_2 = P_3$

Hence

$$\frac{T_4}{T_1} = \frac{P_4}{P_3} \times \frac{P_2}{P_1}$$

Since **1-2** and **3-4** are isentropic processes ($PV^\gamma = C$)

$$\frac{P_4}{P_3} = \left(\frac{V_3}{V_4}\right)^\gamma \quad \text{and} \quad \frac{P_2}{P_1} = \left(\frac{V_1}{V_2}\right)^\gamma$$

Hence

$$\frac{T_4}{T_1} = \left(\frac{V_3}{V_4}\right)^\gamma \left(\frac{V_1}{V_2}\right)^\gamma = \left(\frac{V_3}{V_2}\right)^\gamma = (r_c)^\gamma \quad (5.21)$$

$$\eta = 1 - \frac{\{(r_c)^\gamma - 1\}}{\gamma (r_0)^{\gamma-1} \{r_c - 1\}} \quad (5.22)$$

Also to be noted

$$\frac{T_3}{T_2} = \frac{P_3 V_3}{P_2 V_2} = \frac{V_3}{V_2} = r_c \quad (5.23)$$

The compression ratios normally in the Diesel engines vary between 14 and 17.

AIR STANDARD DUAL CYCLE

Figures 5.4 (a) and (b) shows the working principles of a Dual cycle. In the dual cycle, the energy addition is accomplished in two stages: Part of the energy is added at constant volume and part of the energy is added at constant pressure. The remaining processes are similar to those of the Otto cycle and the Diesel cycle. The efficiency of the cycle can be estimated in the following way

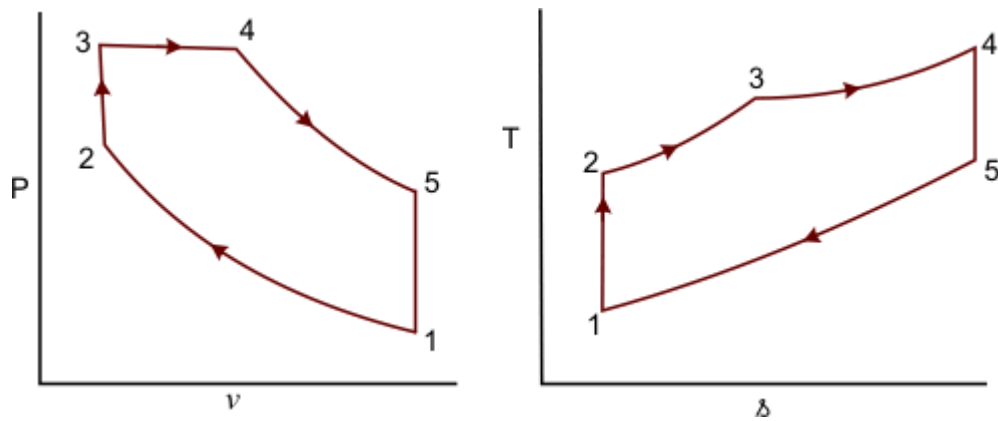

Figure 5.4.1 (a) and (b)

Energy added

$$q_1 = c_v (T_3 - T_2) + c_p (T_4 - T_3) \quad (5.24)$$

Energy rejected

$$q_2 = c_v (T_5 - T_1) \quad (5.25)$$

$$\eta = 1 - \frac{c_v (T_5 - T_1)}{c_v (T_3 - T_2) + c_p (T_4 - T_3)} \quad (5.25)$$

or

$$\eta = 1 - \frac{(T_5 - T_1)}{(T_3 - T_2) + \gamma (T_4 - T_3)} \quad (5.26)$$

The efficiency of the cycle can be expressed in terms of the following ratios

Compression ratio, $r_0 = \frac{V_1}{V_2}$ (5.27)

Cut-off ratio, $r_c = \frac{V_4}{V_3}$ (5.28)

Expansion ratio, $r_e = \frac{V_5}{V_4}$ (5.28)

Constant volume pressure ratio, $r_{vp} = \frac{p_3}{p_2}$ (5.29)

$$\eta_{Dual} = 1 - \frac{1}{(r_0)^{\gamma-1}} \frac{r_{vp} (r_c)^\gamma - 1}{(r_{vp} - 1) + \gamma r_{vp} (r_c - 1)}$$
 (5.30)

If $r_c = 1$, $\eta_{Dual} \rightarrow \eta_{Otto}$

If $r_{vp} = 1$, $\eta_{Dual} \rightarrow \eta_{Diesel}$

Comparison of Otto, Diesel & Dual Cycles

For same compression ratio and heat rejection (Figures 5.5 (a) and (b))

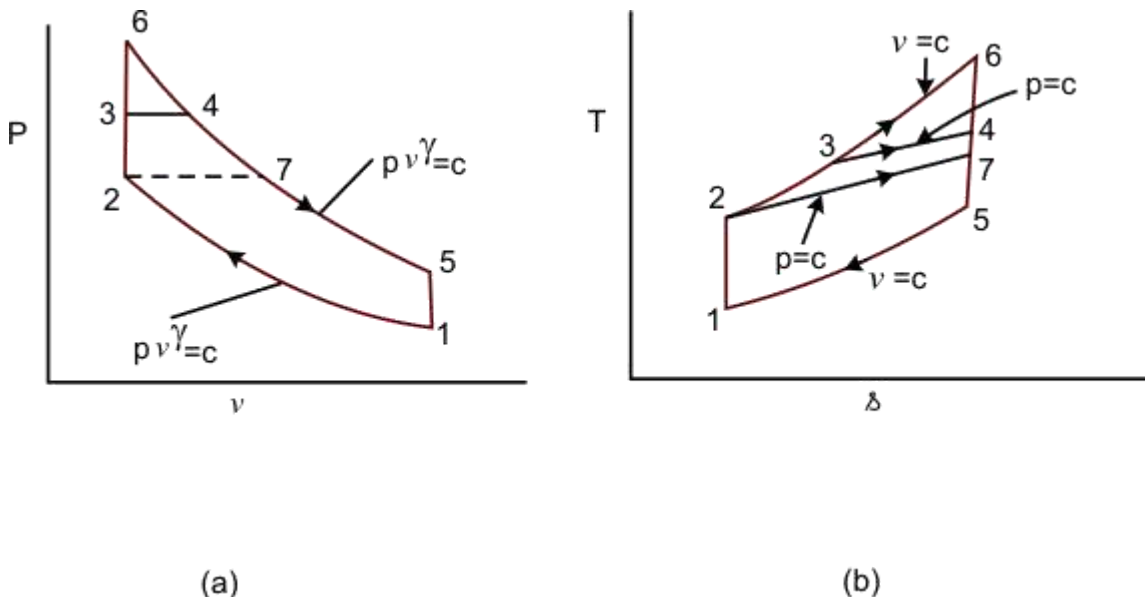

Figure 5.5 (a) and (b)

1-6-4-5: Otto cycle

1-7-4-5: Diesel cycle

1-2-3-4-5 Dual cycle

For the same Q_2 , the higher the Q_1 , the higher is the cycle efficiency

$$\eta_{Otto} > \eta_{Dual} > \eta_{Diesel}$$

For the same maximum pressure and temperature (Figures 5.6 (a) and (b))

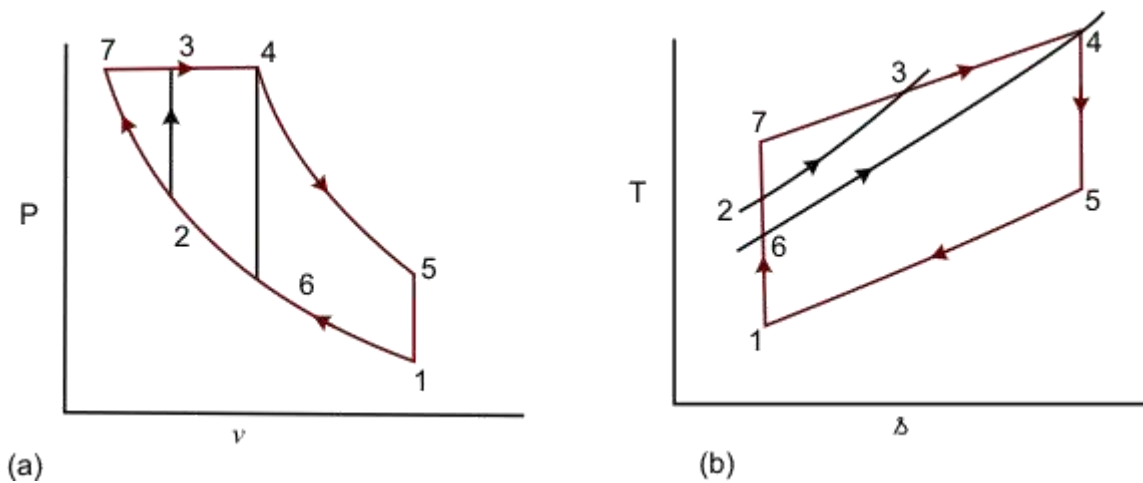

Figure 5.6 (a) and (b)

1-6-4-5: Otto cycle

1-7-4-5: Diesel cycle

1-2-3-4-5 Dual cycle

Q_1 is represented by:

Area under 6-4 \rightarrow for Otto cycle
 area under 7-4 \rightarrow for Diesel cycle

and

area under 2-3-4 \rightarrow for Dual cycle and Q_2 is same for all the cycles

$$\eta_{Diesel} > \eta_{Dual} > \eta_{Otto}$$

The Brayton cycle

The Brayton cycle (or Joule cycle) represents the operation of a gas turbine engine. The cycle consists of four processes, as shown in Figure alongside a sketch of an engine:

- a - b Adiabatic, quasi-static (or reversible) compression in the inlet and compressor;
- b - c Constant pressure fuel combustion (idealized as constant pressure heat addition);
- c - d Adiabatic, quasi-static (or reversible) expansion in the turbine and exhaust nozzle, with which we take some work out of the air and use it to drive the compressor, and take the remaining work out and use it to accelerate fluid for jet propulsion, or to turn a generator for electrical power generation;
- d - a Cool the air at constant pressure back to its initial condition.

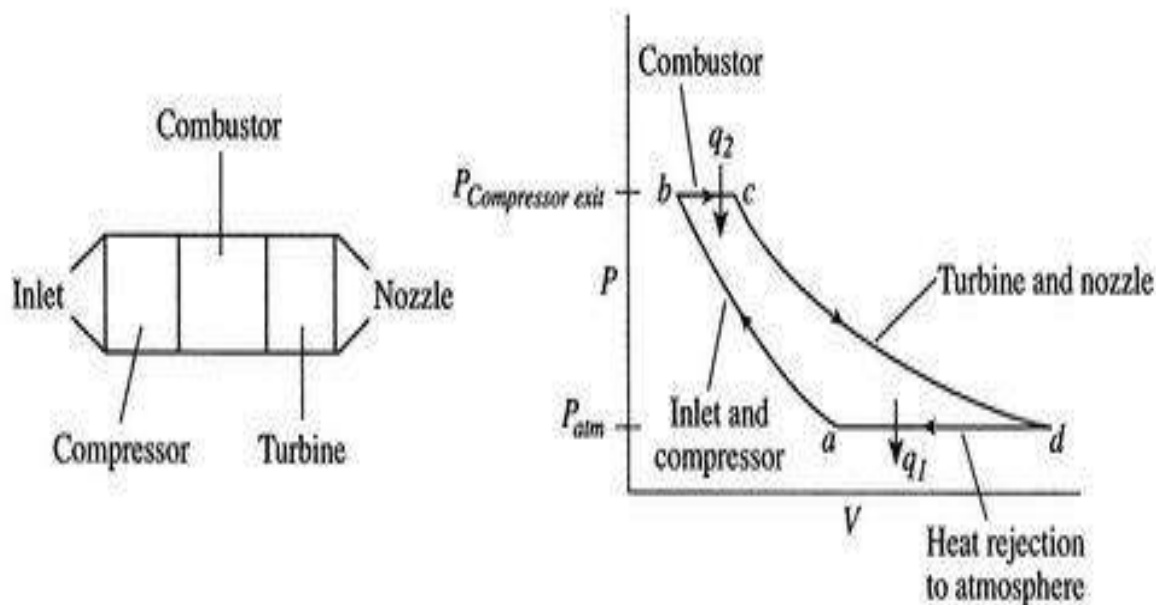

The components of a Brayton cycle device for jet propulsion are shown in Figure 3.14. We will typically represent these components schematically, as in Figure 3.15. In practice, real Brayton cycles take one of two forms. Figure 3.16(a) shows an "open" cycle, where the working fluid enters and then exits the device. This is the way a jet propulsion cycle works. Figure 3.16(b) shows the alternative, a closed cycle, which recirculates the working fluid. Closed cycles are used, for example, in space power generation.

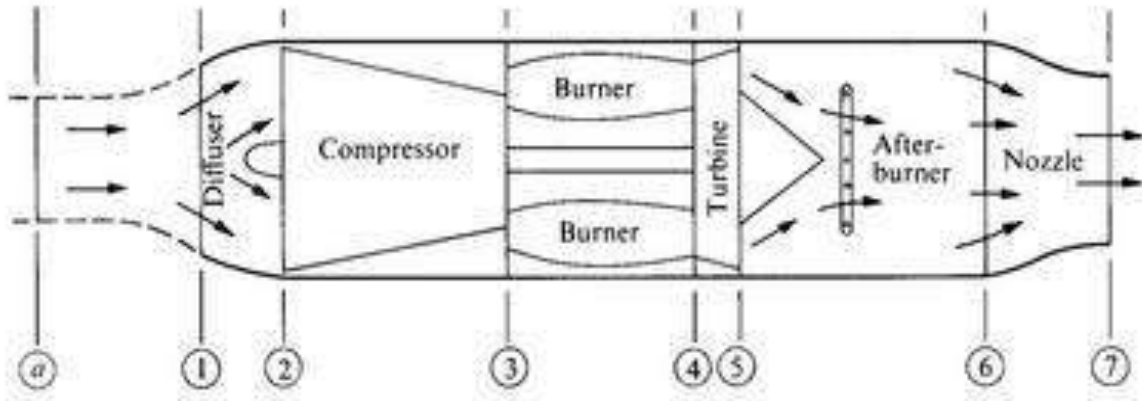

Schematics of typical military gas turbine engines.

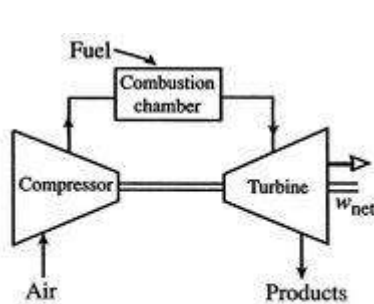
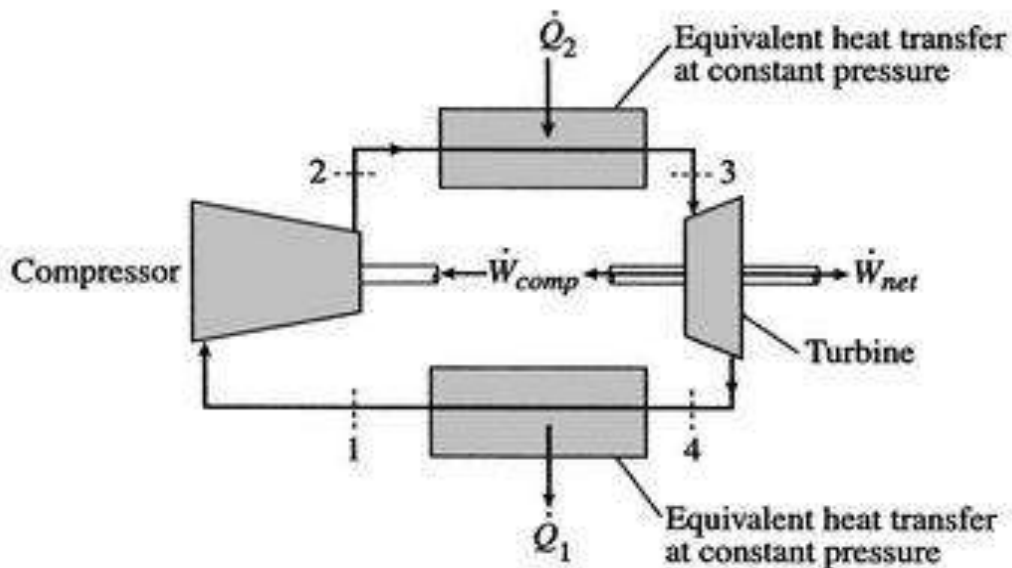

Open cycle operation

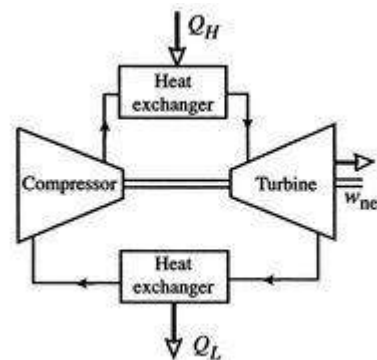

Closed cycle operation

Options for operating Brayton cycle gas turbine engines

Work and Efficiency

The objective now is to find the work done, the heat added and the thermal efficiency of the cycle. Tracing the path shown around the cycle from a - b - c - d and back to a , the first law gives (writing the equation in terms of a unit mass),

$$\Delta u_{a-b-c-d-a} = 0 = q_2 + q_1 - w.$$

Here Δu is zero because u is a function of state, and any cycle returns the system to its starting state^{3,2}. The net work done is therefore

$$w = q_2 + q_1,$$

where q_1 , q_2 are defined as heat received **by** the system (q_1 is negative). We thus need to evaluate the heat transferred in processes $b - c$ and $d - a$.

For a constant pressure, quasi-static process the heat exchange per unit mass is

$$dh = c_p dT = dq, \quad \text{or} \quad [dq]_{\text{constant } P} = dh.$$

We can see this by writing the first law in terms of enthalpy or by remembering the definition of c_p .

The heat exchange can be expressed in terms of enthalpy differences between the relevant states. Treating the working fluid as a perfect gas with constant specific heats, for the heat addition from the combustor,

$$q_2 = h_c - h_b = c_p(T_c - T_b).$$

The heat rejected is, similarly,

$$q_1 = h_a - h_d = c_p(T_a - T_d).$$

The net work per unit mass is given by

$$\text{Net work per unit mass} = q_1 + q_2 = c_p[(T_c - T_b) + (T_a - T_d)].$$

The thermal efficiency of the Brayton cycle can now be expressed in terms of the temperatures:

$$\eta = \frac{\text{Net work}}{\text{Heat in}} = \frac{c_p[(T_c - T_b) - (T_d - T_a)]}{c_p[T_c - T_b]} = 1 - \frac{(T_d - T_a)}{(T_c - T_b)} = 1 - \frac{T_a(T_d/T_a - 1)}{T_b(T_c/T_b - 1)}.$$

To proceed further, we need to examine the relationships between the different temperatures. We know that points *a* and *d* are on a constant pressure process as are points *b* and *c*, and $P_a = P_d$; $P_b = P_c$. The other two legs of the cycle are adiabatic and reversible, so

$$\frac{P_d}{P_c} = \frac{P_a}{P_b} \Rightarrow \left(\frac{T_d}{T_c}\right)^{\gamma/(\gamma-1)} = \left(\frac{T_a}{T_b}\right)^{\gamma/(\gamma-1)}$$

$$T_d/T_c = T_a/T_b \qquad T_d/T_a = T_c/T_b$$

Therefore, or, finally, . Using this relation in the expression for thermal efficiency, Eq. (3.8) yields an expression for the thermal efficiency of a Brayton cycle

Ideal Brayton cycle efficiency: $\eta_B = 1 - \frac{T_a}{T_b} = 1 - \frac{T_{\text{atmospheric}}}{T_{\text{compressor exit}}}$.

$$T_b/T_a = TR$$

The temperature ratio across the compressor, . In terms of compressor temperature ratio, and using the relation for an adiabatic reversible process we can write the efficiency in terms of the compressor (and cycle) pressure ratio, which is the parameter commonly used:

$$\eta_B = 1 - \frac{1}{TR} = 1 - \frac{1}{PR^{(\gamma-1)/\gamma}}$$

THE RANKINE CYCLE

The Rankine cycle is an ideal cycle for vapour power cycles. Many of the impracticalities

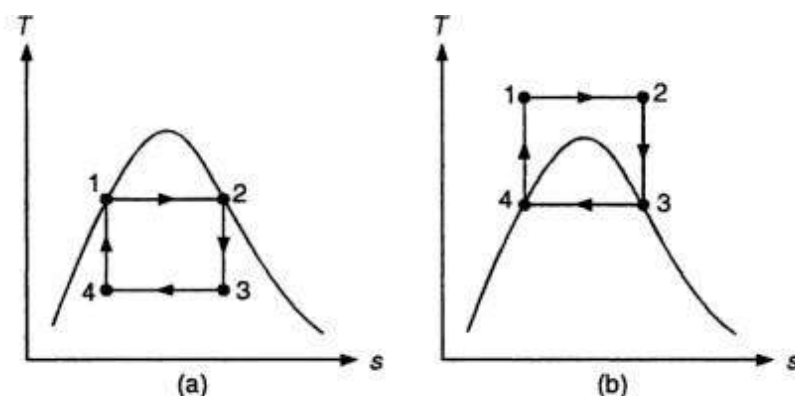

Figure 9.1 T-s diagram of two Carnot vapour cycles.

associated with the Carnot cycle can be eliminated by superheating the steam in the boiler and condensing it completely in the condenser, as shown in Fig. 9.2. The processes involved are:

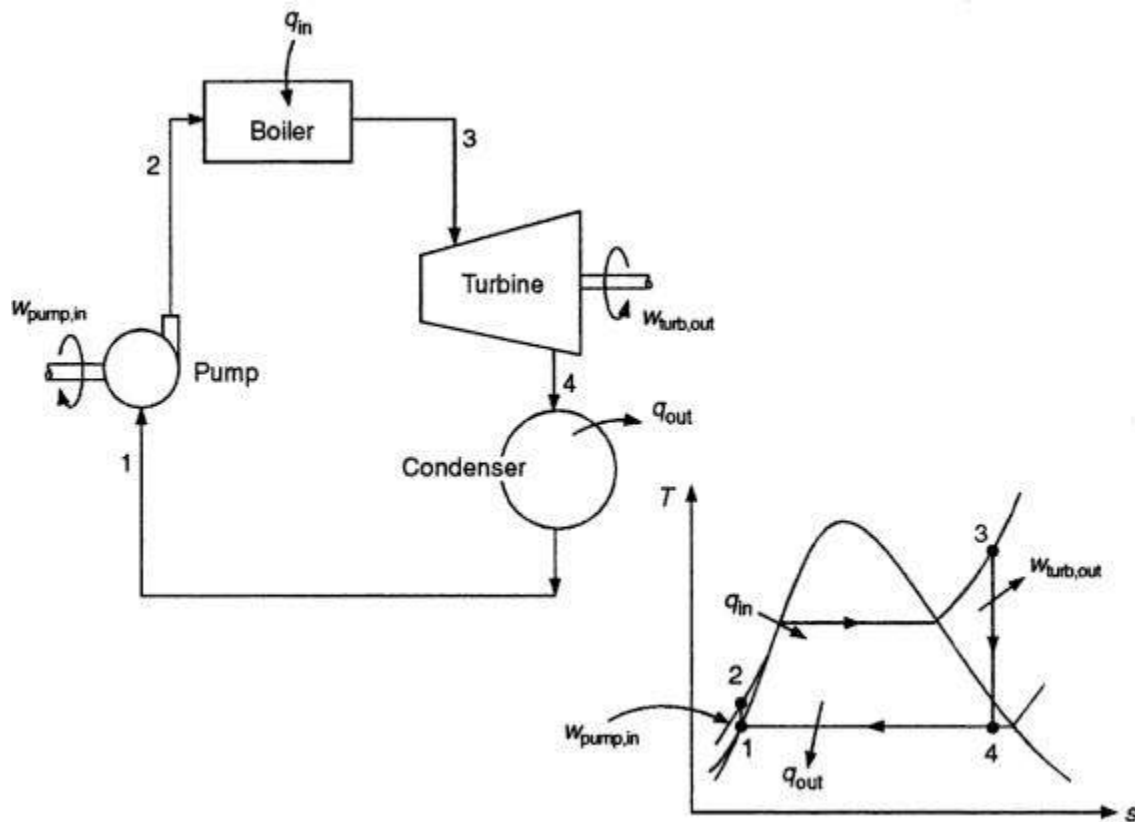

Figure 9.2 The Rankine cycle.

isentropic compression in a pump (1–2), constant pressure heat addition in a boiler (2–3), isentropic expansion in a turbine (3–4), and constant pressure heat rejection in a condenser (4–1). The cycle that results in these processes is the *Rankine cycle*.

The pump, boiler, and condenser associated with a Rankine cycle are steady-flow devices, and thus all the processes of this cycle can be analysed as steady-flow processes. The Δke and

Example 3.30. (a) With the help of $p-v$ and $T-s$ diagram compare the cold air standard otto, diesel and dual combustion cycles for same maximum pressure and maximum temperature. (AMIE Summer, 1998)

Solution. Refer Fig. 3.29. (a, b).

The air-standard Otto, Dual and Diesel cycles are drawn on common $p-v$ and $T-s$ diagrams for the same maximum pressure and maximum temperature, for the purpose of comparison.

Otto 1-2-3-4-1, Dual 1-2'-3'-3-4-1, Diesel 1-2''-3-4-1 (Fig 3.29 (a)).

Slope of constant volume lines on $T-s$ diagram is higher than that of constant pressure lines. (Fig. 3.29 (b)).

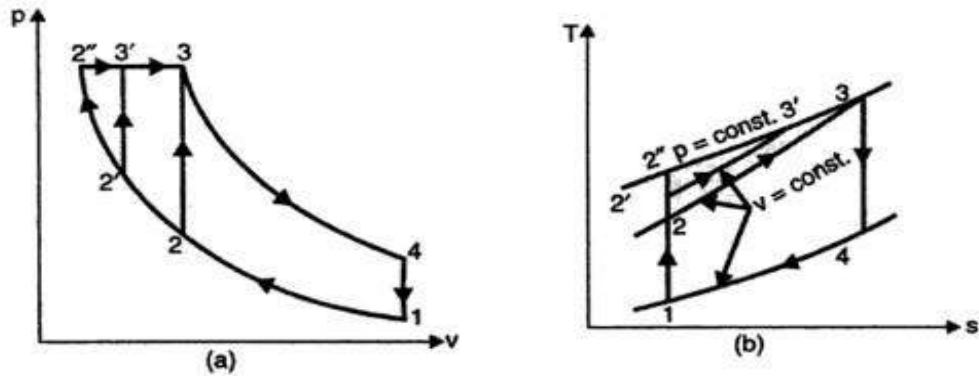

Fig. 3.29

Here the otto cycle must be limited to a low compression ratio (r) to fulfill the condition that point 3 (same maximum pressure and temperature) is to be a common state for all the three cycles.

The construction of cycles on $T-s$ diagram proves that for the given conditions the heat rejected is same for all the three cycles (area under process line 4-1). Since, by definition,

$$\eta = 1 - \frac{\text{Heat rejected, } Q_r}{\text{Heat supplied, } Q_s} = 1 - \frac{\text{Const.}}{Q_s}$$

the cycle, with greater heat addition will be more efficient. From the $T-s$ diagram,

$$Q_{s(\text{diesel})} = \text{Area under } 2''-3$$

$$Q_{s(\text{dual})} = \text{Area under } 2'-3'-3$$

$$Q_{s(\text{otto})} = \text{Area under } 2-3.$$

It can be seen that, $Q_{s(\text{diesel})} > Q_{s(\text{dual})} > Q_{s(\text{otto})}$

and thus, $\eta_{\text{diesel}} > \eta_{\text{dual}} > \eta_{\text{otto}}$

In an engine working on Dual cycle, the temperature and pressure at the beginning of the cycle are 90°C and 1 bar respectively. The compression ratio is 9. The maximum pressure is limited to 68 bar and total heat supplied per kg of air is 1750 kJ. Determine :

- (i) Pressure and temperatures at all salient points
- (ii) Air standard efficiency
- (iii) Mean effective pressure.

Solution. Refer Fig. 3.22.

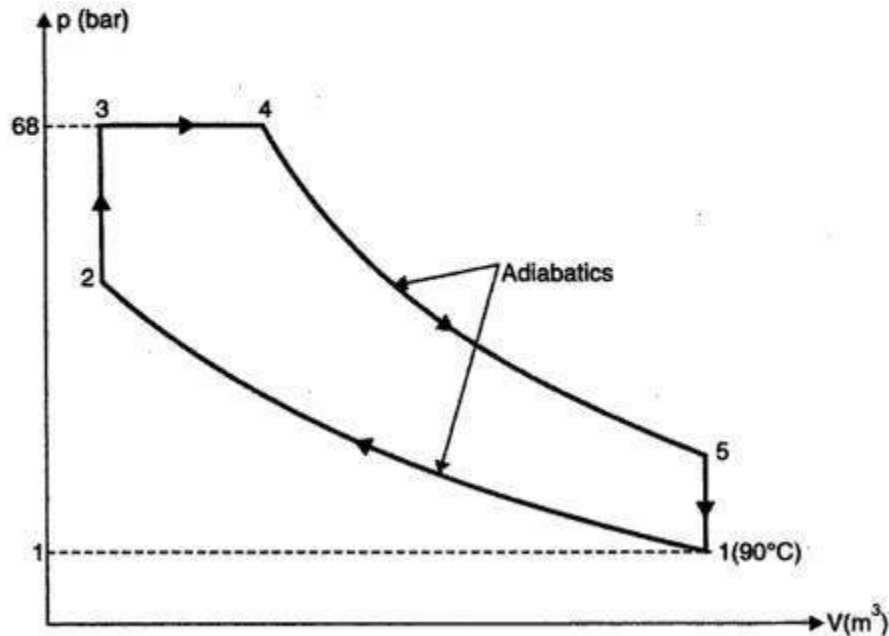

Fig. 3.22

Initial pressure, $p_1 = 1$ bar
 Initial temperature, $T_1 = 90 + 273 = 363$ K
 Compression ratio, $r = 9$
 Maximum pressure, $p_3 = p_4 = 68$ bar
 Total heat supplied = 1750 kJ/kg

(i) **Pressures and temperatures at salient points :**

For the *isentropic process* 1-2,

$$p_1 V_1^\gamma = p_2 V_2^\gamma$$

$$p_2 = p_1 \times \left(\frac{V_1}{V_2} \right)^\gamma = 1 \times (r)^\gamma = 1 \times (9)^{1.4} = 21.67 \text{ bar. (Ans.)}$$

Also,

$$\frac{T_2}{T_1} = \left(\frac{V_1}{V_2} \right)^{\gamma-1} = (r)^{\gamma-1} = (9)^{1.4-1} = 2.408$$

$$\therefore T_2 = T_1 \times 2.408 = 363 \times 2.408 = 874.1 \text{ K. (Ans.)}$$

$$p_3 = p_4 = 68 \text{ bar. (Ans.)}$$

For the *constant volume process* 2-3,

$$\frac{p_2}{T_2} = \frac{p_3}{T_3}$$

$$\therefore T_3 = T_2 \times \frac{p_3}{p_2} = 874.1 \times \frac{68}{21.67} = 2742.9 \text{ K. (Ans.)}$$

Heat added at constant volume

$$= c_v (T_3 - T_2) = 0.71 (2742.9 - 874.1) = 1326.8 \text{ kJ/kg}$$

\(\therefore\) Heat added at constant pressure

$$= \text{Total heat added} - \text{Heat added at constant volume} \\ = 1750 - 1326.8 = 423.2 \text{ kJ/kg}$$

$$\therefore c_p (T_4 - T_3) = 423.2$$

$$1.0 (T_4 - 2742.9) = 423.2$$

$$\therefore T_4 = 3166 \text{ K. (Ans.)}$$

For constant pressure process 3-4,

$$\rho = \frac{V_4}{V_3} = \frac{T_4}{T_3} = \frac{3166}{2742.9} = 1.15$$

For adiabatic (or isentropic) process 4-5,

$$\frac{V_5}{V_4} = \frac{V_5}{V_2} \times \frac{V_2}{V_4} = \frac{V_1}{V_2} \times \frac{V_3}{V_4} = \frac{r}{\rho} \quad \left(\because \rho = \frac{V_4}{V_3} \right)$$

Also

$$p_4 V_4^\gamma = p_5 V_5^\gamma$$

$$\therefore p_5 = p_4 \times \left(\frac{V_4}{V_5} \right)^\gamma = 68 \times \left(\frac{\rho}{r} \right)^\gamma = 68 \times \left(\frac{1.15}{9} \right)^{1.4} = 3.81 \text{ bar. (Ans.)}$$

$$\text{Again, } \frac{T_5}{T_4} = \left(\frac{V_4}{V_5} \right)^{\gamma-1} = \left(\frac{\rho}{r} \right)^{\gamma-1} = \left(\frac{1.15}{9} \right)^{1.4-1} = 0.439$$

$$\therefore T_5 = T_4 \times 0.439 = 3166 \times 0.439 = 1389.8 \text{ K. (Ans.)}$$

(ii) Air standard efficiency :

Heat rejected during constant volume process 5-1,

$$Q_r = C_v (T_5 - T_1) = 0.71 (1389.8 - 363) = 729 \text{ kJ/kg}$$

$$\therefore \eta_{\text{air-standard}} = \frac{\text{Work done}}{\text{Heat supplied}} = \frac{Q_s - Q_r}{Q_s} \\ = \frac{1750 - 729}{1750} = 0.5834 \text{ or } 58.34\%. \text{ (Ans.)}$$

(iii) Mean effective pressure, p_m :

Mean effective pressure is given by

$$p_m = \frac{\text{Work done per cycle}}{\text{Stroke volume}}$$

$$p_m = \frac{1}{V_s} \left[p_3 (V_4 - V_3) + \frac{p_4 V_4 - p_5 V_5}{\gamma - 1} - \frac{p_2 V_2 - p_1 V_1}{\gamma - 1} \right]$$

$$V_1 = V_5 = r V_c, V_2 = V_3 = V_c, V_4 = \rho V_c, \\ V_s = (r - 1) V_c$$

$$\left[\because r = \frac{V_s + V_c}{V_c} = 1 + \frac{V_s}{V_c} \right] \\ \left[\therefore V_s = (r - 1) V_c \right]$$

$$\therefore p_m = \frac{1}{(r-1)V_c} \left[p_3 (\rho V_c - V_c) + \frac{p_4 \rho V_c - p_5 \times r V_c}{\gamma - 1} - \frac{p_2 V_c - p_1 r V_c}{\gamma - 1} \right]$$

$$r = 9, \rho = 1.15, \gamma = 1.4$$

$$p_1 = 1 \text{ bar}, p_2 = 21.67 \text{ bar}, p_3 = p_4 = 68 \text{ bar}, p_5 = 3.81 \text{ bar}$$

Substituting the above values in the above equation, we get

$$p_m = \frac{1}{(9-1)} \left[68(1.15-1) + \frac{68 \times 1.15 - 3.81 \times 9}{1.4-1} - \frac{21.67-9}{1.4-1} \right]$$

$$= \frac{1}{8} (10.2 + 109.77 - 31.67) = 11.04 \text{ bar}$$

Hence, mean effective pressure = 11.04 bar. (Ans.)

A Diesel engine working on a dual combustion cycle has a stroke volume of 0.0085 m³ and a compression ratio 15 : 1. The fuel has a calorific value of 43890 kJ/kg. At the end of suction, the air is at 1 bar and 100°C. The maximum pressure in the cycle is 65 bar and air fuel ratio is 21 : 1. Find for ideal cycle the thermal efficiency. Assume c_p = 1.0 kJ/kg K and c_v = 0.71 kJ/kg K.

Solution. Refer Fig. 3.24.

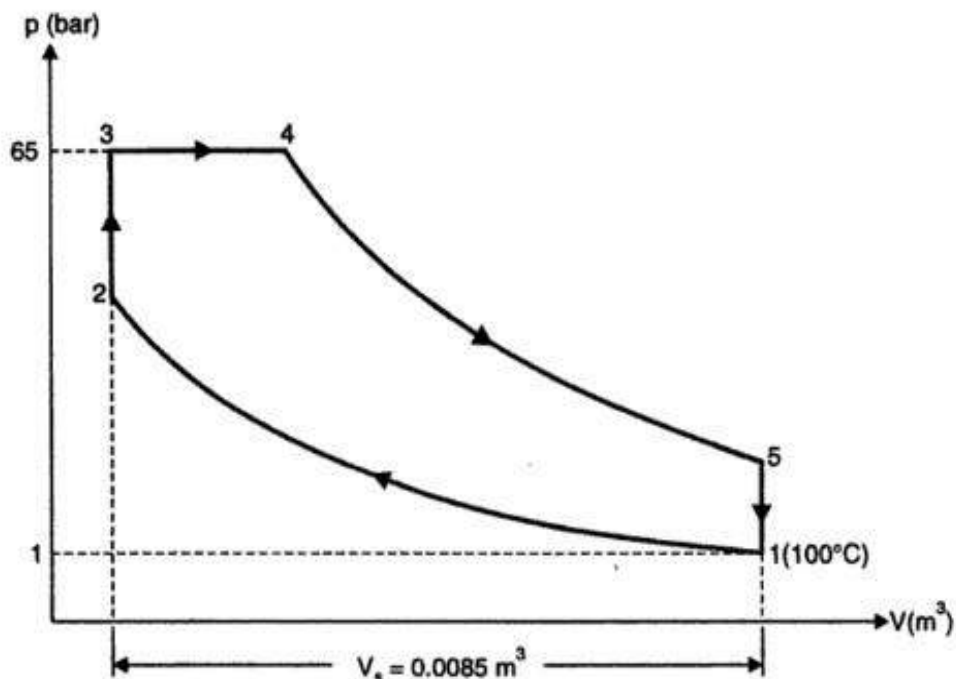

Fig. 3.24

Initial temperature,
Initial pressure,

$$T_1 = 100 + 273 = 373 \text{ K}$$

$$p_1 = 1 \text{ bar}$$

Maximum pressure in the cycle, $p_3 = p_4 = 65$ bar
 Stroke volume, $V_s = 0.0085$ m³
 Air-fuel ratio = 21 : 1
 Compression ratio, $r = 15 : 1$
 Calorific value of fuel, $C = 43890$ kJ/kg
 $c_p = 1.0$ kJ/kg K, $c_v = 0.71$ kJ/kg K

Thermal efficiency :

$$V_s = V_1 - V_2 = 0.0085 \text{ m}^3$$

and as

$$r = \frac{V_1}{V_2} = 15, \text{ then } V_1 = 15V_2$$

\therefore

$$15V_2 - V_2 = 0.0085$$

or

$$14V_2 = 0.0085$$

or

$$V_2 = V_3 = V_c = \frac{0.0085}{14} = 0.0006 \text{ m}^3$$

For *adiabatic compression process 1-2,*

$$p_1 V_1^\gamma = p_2 V_2^\gamma$$

or

$$p_2 = p_1 \cdot \left(\frac{V_1}{V_2} \right)^\gamma = 1 \times (15)^{1.41} \quad \left[\gamma = \frac{c_p}{c_v} = \frac{1.0}{0.71} = 1.41 \right]$$

$$= 45.5 \text{ bar}$$

Also,

$$\frac{T_2}{T_1} = \left(\frac{V_1}{V_2} \right)^{\gamma-1} = (r)^{\gamma-1} = (15)^{1.41-1} = 3.04$$

\therefore

$$T_2 = T_1 \times 3.04 = 373 \times 3.04 = 1134 \text{ K or } 861^\circ\text{C}$$

For *constant volume process 2-3,*

$$\frac{p_2}{T_2} = \frac{p_3}{T_3}$$

or

$$T_3 = T_2 \times \frac{p_3}{p_2} = 1134 \times \frac{65}{45.5} = 1620 \text{ K or } 1347^\circ\text{C}$$

According to characteristic equation of gas,

$$p_1 V_1 = mRT_1$$

\therefore

$$m = \frac{p_1 V_1}{RT_1} = \frac{1 \times 10^5 \times 0.009}{287 \times 373} = 0.0084 \text{ kg (air)}$$

Heat added during constant volume process 2-3,

$$= m \times c_v (T_3 - T_2)$$

$$= 0.0084 \times 0.71 (1620 - 1134)$$

$$= 2.898 \text{ kJ}$$

Amount of fuel added during the *constant volume process 2-3,*

$$= \frac{2.898}{43890} = 0.000066 \text{ kg}$$

Also as air-fuel ratio is 21 : 1.

$$\therefore \text{Total amount of fuel added} = \frac{0.0084}{21} = 0.0004 \text{ kg}$$

$$\begin{aligned} \text{Quantity of fuel added during the process 3-4,} \\ = 0.0004 - 0.000066 = 0.000334 \text{ kg} \end{aligned}$$

$$\begin{aligned} \therefore \text{Heat added during the constant pressure operation 3-4} \\ = 0.000334 \times 43890 = 14.66 \text{ kJ} \end{aligned}$$

$$\begin{aligned} \text{But } (0.0084 + 0.0004) c_p (T_4 - T_3) &= 14.66 \\ 0.0088 \times 1.0 (T_4 - 1620) &= 14.66 \end{aligned}$$

$$\therefore T_4 = \frac{14.66}{0.0088} + 1620 = 3286 \text{ K or } 3013^\circ\text{C}$$

Again for operation 3-4,

$$\frac{V_3}{T_3} = \frac{V_4}{T_4} \quad \text{or} \quad V_4 = \frac{V_3 T_4}{T_3} = \frac{0.0006 \times 3286}{1620} = 0.001217 \text{ m}^3$$

For adiabatic expansion operation 4-5,

$$\frac{T_4}{T_5} = \left(\frac{V_5}{V_4} \right)^{\gamma-1} = \left(\frac{0.009}{0.001217} \right)^{1.41-1} = 2.27$$

or

$$T_5 = \frac{T_4}{2.27} = \frac{3286}{2.27} = 1447.5 \text{ K or } 1174.5^\circ\text{C}$$

Heat rejected during constant volume process 5-1,

$$\begin{aligned} &= m c_v (T_5 - T_1) \\ &= (0.00854 + 0.0004) \times 0.71 (1447.5 - 373) = 6.713 \text{ kJ} \end{aligned}$$

Work done

$$\begin{aligned} &= \text{Heat supplied} - \text{Heat rejected} \\ &= (2.898 + 14.66) - 6.713 = 10.845 \text{ kJ} \end{aligned}$$

\therefore Thermal efficiency,

$$\eta_{th} = \frac{\text{Work done}}{\text{Heat supplied}} = \frac{10.845}{(2.898 + 14.66)} = 0.6176 \text{ or } 61.76\%. \quad (\text{Ans.})$$

EXAMPLE 9.1

A steam power plant operates between a boiler pressure of 4 MPa and 300°C and a condenser pressure of 50 kPa. Determine the thermal efficiency of the cycle, the work ratio, and the specific steam flow rate, assuming (a) the cycle to be a Carnot cycle, and (b) a simple ideal Rankine cycle.

Solution

(a) The T - s diagram of a Carnot cycle is shown in the adjacent figure.

Process 1-2 is reversible and isothermal heating of water in the boiler.

Process 2-3 is isentropic expansion of steam at state 2 in the turbine.

Process 3-4 is reversible and isothermal condensation of steam in the condenser.

Process 4-1 is isentropic compression of steam to initial state.

At state 1: $P_1 = 4 \text{ MPa}$, $T_1 = 300^\circ\text{C}$

At state 2: $P_2 = 50 \text{ kPa}$, the steam is in a saturated state.

From the saturated water-pressure table (Table 4 of the Appendix), at 50 kPa, we get $T_2 = T_{\min} = T_{\text{sat}} = 81.33^\circ\text{C}$

Δp_e of the steam are usually small compared with the work and heat transfer terms and are, therefore, neglected. Thus, the steady-flow energy equation per unit mass of steam is

$$q - w = h_e - h_i \quad (\text{kJ/kg}) \quad (9.1)$$

Assuming the pump and turbine to be isentropic and noting that there is no work associated with the boiler and the condenser, the energy conservation relation for each device becomes

$$w_{\text{pump,in}} = h_2 - h_1 = v(P_2 - P_1) \quad (9.2)$$

$$q_{\text{boi,in}} = h_3 - h_2 \quad (9.3)$$

$$w_{\text{turb,out}} = h_3 - h_4 \quad (9.4)$$

$$q_{\text{cond,out}} = h_4 - h_1 \quad (9.5)$$

The thermal efficiency of the Rankine cycle is given by

$$\eta_{\text{th}} = \frac{w_{\text{net}}}{q_{\text{in}}} = 1 - \frac{q_{\text{out}}}{q_{\text{in}}} \quad (9.6)$$

where $w_{\text{net}} = q_{\text{in}} - q_{\text{out}} = w_{\text{turb,out}} - w_{\text{pump,in}}$

The η_{th} can also be interpreted as the ratio of the area enclosed by the cycle on a T - s diagram to the area under the heat addition process.

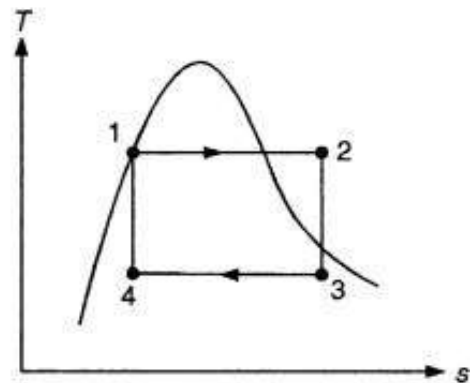

Therefore, the thermal efficiency for the given Carnot cycle is

$$\eta_{th,carnot} = 1 - \frac{T_{min}}{T_{max}} = 1 - \frac{81.33 + 273.15}{300 + 273.15} = 0.3815$$

$$= \boxed{38.15 \text{ per cent}}$$

$$\text{The work ratio} = \frac{\text{net work output}}{\text{gross work output}} = \frac{W_{net,out}}{W_{gross,out}}$$

Heat supplied = $h_2 - h_1 = h_{fg @ 4MPa} = 1714.1 \text{ kJ/kg}$ (From Table 4 of the Appendix)

$$\eta_{th,carnot} = \frac{W_{net,out} - W_{net,in}}{\text{gross heat supplied}} = 0.3815$$

Therefore,

$$W_{net,out} - W_{net,in} = 0.3815 \times 1714.1 = 653.9 \text{ kJ/kg}$$

That is, the net work output = 653.9 kJ/kg.

To find the expansion work for the process 2-3, h_3 is required.

From Table 4, $h_2 = 2801.4 \text{ kJ/kg}$ and $s_2 = s_3 = 6.0701 \text{ kJ/(kg K)}$

$$\text{But } s_3 = 6.0701 = s_{f3} + x_3 s_{fg3} = 1.0910 + x_3(7.5939 - 1.0910)$$

or

$$x_3 = 0.766$$

Now,

$$h_3 = h_{f3} + x_3 h_{fg3} = 340.49 + 0.766(2645.9 - 340.49) = 2106.4 \text{ kJ/kg}$$

Therefore,

$$w_{32} = h_2 - h_3 = 2801.4 - 2106.4 = 695 \text{ kJ/kg}$$

That is, the gross work output, $w_{gross,out} = 695 \text{ kJ/kg}$

Therefore,

$$\text{Work ratio} = \frac{W_{net,out}}{W_{gross,out}} = \frac{653.9}{695} = \boxed{0.94}$$

The specific steam flow rate (ssfr) is the steam flow required to develop unit power output. That is,

$$\text{ssfr} = \frac{\dot{m}_{\text{steam}}}{\dot{m}_s W_{out}} = \frac{1}{W_{net,out}}$$

$$= \frac{1}{653.9} = \boxed{0.00153 \text{ kg/kW}}$$

A steam power plant operates on the cycle shown below with 3 MPa and 400°C at the turbine inlet and 10 kPa at the turbine exhaust. The adiabatic efficiency of the turbine is 85 per cent and that of the pump is 80 per cent. Determine (a) the thermal efficiency of the cycle, and (b) the mass flow rate of the steam if the power output is 20 MW.

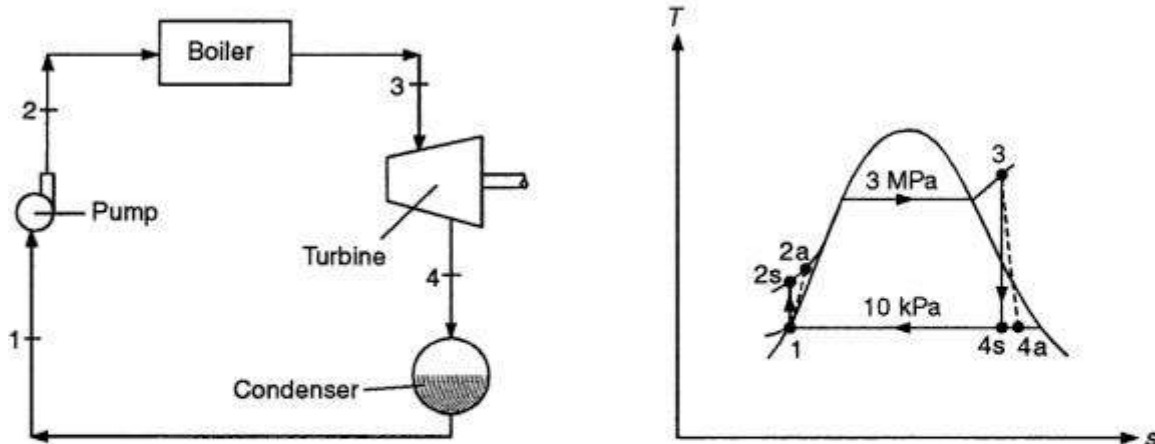

Solution

All the components are treated as steady-flow devices. The changes, if any, in the kinetic and potential energies are assumed to be negligible. Losses other than those in the turbine and pump are neglected.

$$(a) \quad w_{\text{pump,in}} = \frac{v_1(P_2 - P_1)}{\eta_P} = \frac{0.001010(3000 - 10)}{0.80} = 3.77 \text{ kJ/kg}$$

Turbine work output is

$$\begin{aligned} w_{\text{turb,out}} &= \eta_T w_{\text{turb,in}} = \eta_T (h_3 - h_{4s}) \\ &= 0.85(3230.90 - 2192.21) = 882.89 \text{ kJ/kg} \end{aligned}$$

Boiler heat input is

$$q_{\text{in}} = h_3 - h_2 = 3230.9 - 195.59 = 3035.31 \text{ kJ/kg}$$

Thus,

$$w_{\text{net,out}} = w_{\text{turb,out}} - w_{\text{pump,in}} = 882.89 - 3.77 = 879.12 \text{ kJ/kg}$$

$$\eta_{\text{th}} = \frac{w_{\text{net,out}}}{q_{\text{in}}} = \frac{879.12}{3035.31} = 0.2896 = \boxed{28.96 \text{ per cent}}$$

If there are no losses in the turbine and the pump, the thermal efficiency would be 28.99 per cent.

(b) The power generated by the power plant is

$$\dot{W}_{\text{net,out}} = \dot{m} w_{\text{net,out}} = 20,000 \text{ kW}$$

$$\text{Therefore, the mass flow rate, } \dot{m} = \frac{20,000}{879.12} = \boxed{22.75 \text{ kg/s}}$$

Industry applications

- Automobile industries.
- Refrigeration industries
- Air craft applications
- Defense industries
- Thermal power plants etc.

Assignment Questions

1. With p-V and T-s diagrams derive the efficiency of otto cycle.
2. With p-V and T-s diagrams derive the efficiency of Diesel cycle.
3. With p-V and T-s diagrams derive the efficiency of dual combustion cycle.
4. Differentiate between Otto cycle, diesel cycle and dual combustion cycle.
5. With p-V and T-s diagrams derive the efficiency of Rankine cycle.
6. An engine working on Otto cycle has a volume of 0.45 m^3 , pressure 1 bar and temperature 30°C at the beginning of compression stroke. At the end of compression stroke, the pressure is 11 bar. 210 kJ of heat is added at constant volume. Determine:
 - a. Pressures, temperatures and volumes at salient points in the cycle.
 - b. Percentage clearance.
 - c. Efficiency.
 - d. Mean effective pressure.
7. In a Diesel cycle, air at 0.1 MPa and 300 K is compressed adiabatically until the pressure rises to 5 MPa . If 700 kJ/kg of energy in the form of heat is supplied at constant pressure, determine the compression ratio, cutoff ratio, thermal efficiency and mean effective pressure.
8. An air-standard Diesel cycle has a compression ratio of 20, and the heat transferred to the working fluid per cycle is 1800 kJ/kg . At the beginning of the compression process, the pressure is 0.1 MPa and the temperature is 15°C . Consider ideal gas and constant specific heat model. Determine the pressure and temperature at each point in the cycle, The thermal efficiency, The mean effective pressure.

Tutorial Questions

1. An engine working on Otto cycle has a volume of 0.45 m^3 , pressure 1 bar and temperature 30°C at the beginning of compression stroke. At the end of compression stroke, the pressure is 11 bar. 210 kJ of heat is added at constant volume. Determine:
 - a. Pressures, temperatures and volumes at salient points in the cycle.
 - b. Percentage clearance.
 - c. Efficiency.
 - d. Mean effective pressure.
2. In a Diesel cycle, air at 0.1 MPa and 300 K is compressed adiabatically until the pressure rises to 5 MPa. If 700 kJ/kg of energy in the form of heat is supplied at constant pressure, determine the compression ratio, cutoff ratio, thermal efficiency and mean effective pressure.
3. An air-standard Diesel cycle has a compression ratio of 20, and the heat transferred to the working fluid per cycle is 1800 kJ/kg. At the beginning of the compression process, the pressure is 0.1 MPa and the temperature is 15°C . Consider ideal gas and constant specific heat model. Determine the pressure and temperature at each point in the cycle, The thermal efficiency, The mean effective pressure.
4. An engine with 200mm cylinder diameter and 300mm stroke working on theoretical diesel cycle. The initial pressure and temperature of air used are 1bar and 270°C . The cut off is 8% of the stroke. Determine air standard efficiency, mean effective pressure and power of the engine if the working cycles per minute are 300? Assume the compression ratio is 15 and the working fluid is air.
5. An engine of 250mm bore and 375mm stroke works on Otto cycle. The clearance volume is 0.00263 m^3 . The initial pressure and temperature are 1bar and 500°C . The maximum pressure is limited to 25bar. Find the air standard efficiency and the mean effective pressure of the cycle? Assume ideal conditions?

QUESTION BANK

UNIT-I

1. Explain briefly the following terms with diagram (wherever necessary)
 - a. Thermodynamic System, Surroundings & Boundary
 - b. Control Volume & Control Surface
 - c. Intensive & Extensive Property
 - d. Path Function & Point Function
 - e. Thermodynamic Equilibrium
2. Describe the working principle of constant volume gas thermometer with a neat sketch.
3. State and explain quasi- static process.
4. List out the causes of irreversibility and explain.
5. State and explain first law of thermodynamics with its corollaries.
6. Prove that 'Energy' is a point function of a system undergoing change of state.
7. A stationary mass of gas is compressed without friction from an initial state of 0.35 m³ and 0.11MPa to a final state of 0.25 m³ at constant pressure. There is a transfer of 48.67 kJ of heat from the gas during the process. How much does the internal energy of the gas change?
8. 0.2m³ of air at 3 bar and 120⁰C is contained in a system. A reversible adiabatic expansion takes place till the pressure falls to 1.5 bar. The gas is then heated at constant pressure till enthalpy increases by 75 kJ. Calculate the work done and the index of expansion, if the above processes are replaced by a single reversible polytropic process giving the same work between the same initial and final states.

UNIT-II

1. Write notes on the following a) Limitations of first law of thermodynamics b) Thermal energy reservoir c) Heat engine d) Heat pump e) COP
2. State and explain second law of thermodynamics with its corollaries.
3. Explain Carnot cycle with p-V and T-s diagrams and derive the expression for efficiency.
4. Describe briefly about Maxwell's equations.
5. What is reversed Carnot heat engine? What are the limitations of Carnot cycle?
6. At the inlet to a certain nozzle the enthalpy of fluid passing is 2800 kJ/kg, and the velocity is 50 m/s. At the discharge end the enthalpy is 2600 kJ/kg. The nozzle is horizontal and there is negligible heat loss from it.
 - a. Find the velocity at exit of the nozzle.
 - b. If the inlet area is 900 cm² and the specific volume at inlet is 0.187 m³/kg, find the mass flow rate.
 - c. If the specific volume at the nozzle exit is 0.498 m³/kg, find the exit area of nozzle.
7. A **steam turbine** operates under steady flow conditions receiving steam at the following state:
 - a. pressure 15 bar, internal energy 2700 kJ/kg, specific volume 0.17 m³/kg

and velocity 100 m/s. the exhaust of steam from the turbine is at 0.1 bar with internal energy 2175 kJ/kg, specific volume $0.15 \text{ m}^3/\text{kg}$ and velocity 300 m/s. The intake is 3 meters above the exhaust. The turbine develops 35 kW and heat loss over the surface of turbine is 20 kJ/kg. Determine the steam flow rate through the turbine.

8. A reversible engine receives heat from two thermal reservoirs maintained at constant temperature of 750 K and 500 K. The engine develops 100 kW and rejects 3600 kJ/min of heat to a heat sink at 250 K. Determine thermal efficiency of the engine and heat supplied by each thermal reservoir.

UNIT-III

1. Explain the phase change of a pure substance on p-V-T surface.
2. Describe briefly about mollier chart.
3. Describe the working of combined separating and throttling calorimeter.
4. Explain briefly about the vanderwaals equation of state.
5. 2 kg. of gas at a temperature of 20°C undergoes a constant pressure process until the temperature is 100°C . Find the heat transferred, ratio of specific heats, specific gas constant, work done, and change in entropy during the process. Take $C_v = 0.515 \text{ kJ/kg k}$, $C_p = 0.6448 \text{ kJ/kgk}$.
6. A container of 2 m³ capacity contains 10 kg of CO₂ at 27°C. Estimate the pressure exerted by CO₂ by using, a) Perfect gas equations and also using b) vanderwaals equation
7. Atmospheric air at 1.0132 bar has a DBT of 30°C and WBT of 24°C. Compute,
 - (i) The partial pressure of water vapour
 - (ii) Specific humidity
 - (iii) The dew point temperature
 - (iv) Relative humidity
 - (v) Degree of saturation
 - (vi) Density of air in the mixture
 - (vii) Density of the vapour in the mixture
8. A vessel of 0.04 m² Contains a mixture of saturated water and saturated steam at a temperature of 250°C. The Mass liquid present is 9kg . Find pressure, the mass, the specific volume, the enthalpy and entropy and the internal energy.

UNIT-IV

1. Write notes on the following terms a) Mole Fraction b) Mass fraction c) Gravimetric and d) volumetric Analysis.
2. Write notes on the following terms a) Dry bulb Temperature b)Wet Bulb Temperature, c) Dew point Temperature d)Thermodynamic Wet Bulb Temperature e) Specific Humidity f)Relative Humidity
3. Explain the various terms involved psychrometric chart.
4. 2 kg. of gas at a temperature of 20 0 C undergoes a constant pressure process until the temperature is 100 0 C. Find the heat transferred, ratio of specific heats, specific

gas constant, work done, and change in entropy during the process. Take $C_v = 0.515$ kJ/kgk $C_p = 0.6448$ kJ/kg k.

5. a) Write the differences between gravimetric and volumetric analysis.
b) 1.8 kg of oxygen at 48°C is mixed with 6.2 kg of nitrogen at the same temperature. Both oxygen and nitrogen are at the pressure of 102 k Pa before and after mixing. Find the increase in entropy.
6. A mixture of ideal air and water vapour at a DBT of 22°C and a total pressure of 730 mm Hg abs has a temperature of adiabatic saturation of 15°C . Calculate, (i) The specific humidity in gms per kg of dry air. (ii) The partial pressure of water vapour. (iii) The relative humidity (iv) Enthalpy of the mixture per kg of dry air.
7. An air-water vapour mixture enters an adiabatic saturator at 30°C and leaves at 20°C , which is the adiabatic saturation temperature. The pressure remains constant at 100 kPa. Determine the relative humidity and the humidity ratio of the inlet mixture.
8. State and explain Daltons' law of partial pressures and Amgot's law of additive volumes.

UNIT-V

6. With p-V and T-s diagrams derive the efficiency of otto cycle.
7. With p-V and T-s diagrams derive the efficiency of Diesel cycle.
8. With p-V and T-s diagrams derive the efficiency of dual combustion cycle.
9. Differentiate between Otto cycle, diesel cycle and dual combustion cycle.
10. With p-V and T-s diagrams derive the efficiency of Rankine cycle.
11. An engine working on Otto cycle has a volume of 0.45 m^3 , pressure 1 bar and temperature 30°C at the beginning of compression stroke. At the end of compression stroke, the pressure is 11 bar. 210 kJ of heat is added at constant volume. Determine:
 - a. Pressures, temperatures and volumes at salient points in the cycle.
 - b. Percentage clearance.
 - c. Efficiency.
 - d. Mean effective pressure.
12. In a Diesel cycle, air a 0.1 MPa and 300 K is compressed adiabatically until the pressure rises to 5 MPa. If 700 kJ/kg of energy in the form of heat is supplied at constant pressure, determine the compression ratio, cutoff ratio, thermal efficiency and mean effective pressure.
13. An air-standard Diesel cycle has a compression ratio of 20, and the heat transferred to the working fluid per cycle is 1800 kJ/kg. At the beginning of the compression process, the pressure is 0.1 MPa and the temperature is 15°C . Consider ideal gas and constant specific heat model. Determine the pressure and temperature at each point in the cycle, The thermal efficiency, The mean effective pressure.

PROJECTS

1. Fabrication of Solar air conditioning Machine
2. A Project on Water cooler cum Water heater by using refrigeration System
3. Improving the performance of an engine block for various cooling fluids.
4. A Project on Fabrication of double reflection solar Cooker
5. Experimental Investigation of Heat Recovery from R744 based Refrigeration System
6. Power Generation from Railway Track
7. Air powered cars
8. Air Powered Bike

Video links

1. <https://www.youtube.com/watch?v=qTYGloPSGec>
2. https://www.youtube.com/watch?v=vJ_rsimoXV4
3. <https://www.youtube.com/watch?v=JQLkiErH9x4&feature=youtu.be>
4. <https://www.youtube.com/watch?v=cdccGqpcNRw>
5. <https://www.youtube.com/watch?v=b5xR9rm6Zuc>
6. https://www.youtube.com/watch?v=0VRD_ihjEBY
7. <https://www.youtube.com/watch?v=uRpxhIX4Ga0>
8. <https://www.youtube.com/watch?v=UC3GtQjUplI>